



Single-Phase Hybrid Inverter

3 kW 3.68 kW 4 kW 4.6 kW 5 kW 6 kW

Trademarks

 **ENERGY** and other Yinergy trademarks used in this manual are owned by Yinergy Digital Power Technology Co., Ltd. All other trademarks or registered trademarks mentioned in this manual are the property of their respective owners.

Notice

Due to product version upgrades or other reasons, the content of the document may be subject to periodic updates. Unless otherwise agreed, the document content cannot replace the safety precautions in the product label or user manual.

All descriptions in the documentation are intended solely as guidelines for usage.

Scope of Validity

This manual is an integral part of Single-phase Hybrid Inverter. It describes the installation, electrical connection, commissioning, maintenance and troubleshooting of the product. Please read it carefully before operating.

This manual is valid for the following inverter models:

- HI-1P3K-L-Y1
- HI-1P3.68K-L-Y1
- HI-1P4K-L-Y1
- HI-1P4.6K-L-Y1
- HI-1P5K-L-Y1
- HI-1P6K-L-Y1

Model Description

HI - 1P6K - L - Y1

1 2 3 4 5

- | | | |
|---|-----------------------|--|
| 1 | Product Type | "HI" refers to hybrid inverter. |
| 2 | Grid Type | "1P" refers to single phase. |
| 3 | Rated Power | "3K" refers to the rated output power of 3 kW. |
| 4 | Battery Type | "L" refers to low voltage battery. |
| 5 | Version Number | "Y1" refers to the first version. |

Target Group

Only for professionals who are familiar with local regulations, standards and electrical systems, and who have received professional training and knowledge of this product.

Symbol Description

Different levels of warning messages in this manual are defined as follows:



DANGER!

Indicates a high-level hazard that, if not avoided, will result in death or serious injury.



WARNING!

Indicates a medium-level hazard that, if not avoided, could result in death or serious injury.



CAUTION!

Indicates a low-level hazard that, if not avoided, could result in minor or moderate injury.



NOTICE

Provide important operation information and techniques for high efficient, proper using and maintenance.

Change History

Version 4.0 (2026-06-08)

Change the password retrieval method; Change System Overview; Delete parallel-related operation; Change Dongle WiFi name; Only reserve DRM0; Add meter info; Add APP UI including reconnection frequency, inverter version, anti-backflow, etc.; Update earth fault alarm; Add supplementary info for 3kW model.

Version 3.0 (2025-10-30)

Update nameplate; Add description for DC breaker in wiring diagram; Update description for carrying inverter; Add password setting for grid setting in APP; Move Chapter 9.4 to 11.3.7; Modify parameters;

Version 2.0 (2025-06-30)

Change the appearance, change the wiring diagram, change the WiFi-Dongle description, add Q(P), Q(U), P(U), P(F) mode, and modify grid code.

Version 1.0 (2024-07-01)

Initial release

Table of Contents

1	Safety	1
1.1	General Safety.....	1
1.2	PV String Safety.....	2
1.3	Inverter Safety.....	2
1.4	Battery Safety	3
1.5	Personal Requirements.....	3
2	Product Overview	4
2.1	System Description.....	4
2.2	Appearance.....	4
2.3	Supported Power Grid.....	5
2.4	Symbols on the Label and Inverter	5
2.5	Nameplate.....	6
2.6	Working Principle	7
2.7	Interfaces and Functions.....	8
2.8	Working Mode.....	11
3	System Overview.....	15
4	Transportation and Storage.....	16
5	Preparation Before Installation	17
5.1	Selection of Installation Location.....	17
5.2	Environment Requirement.....	17
5.3	Installation Carrier Requirement.....	18
5.4	Installation Angle Requirement.....	18
5.5	Tools Requirement	19
5.6	Additionally Required Materials.....	20
6	Unpacking and Inspection.....	21
6.1	Unpacking	21
6.2	Scope of Delivering.....	22
7	Mechanical Installation.....	24
7.1	Dimensions of Mounting	24
7.2	Installation Procedures.....	25
8	Electrical Connections.....	28
8.1	Terminals of Inverter.....	28
8.2	Grounding Connection.....	29

8.3	AC Connection.....	31
8.4	PV Connection.....	35
8.5	Battery Connection.....	37
8.6	Communication Connection.....	40
8.7	BMS, Smart Meter and CT Connection.....	43
9	System Commissioning	45
9.1	Check Before Power-on.....	45
9.2	Powering on the System.....	45
9.3	Operation of Lockable DC Switch.....	46
10	Introduction of LED.....	48
11	Operation on Yinergy Cloud	50
11.1	Introduction of Yinergy Cloud.....	50
11.2	Operation on Yinergy Cloud Web.....	50
11.3	Operation on Yinergy Cloud APP.....	51
11.3.1	Downloading and Installing APP.....	51
11.3.2	Registration.....	51
11.3.3	Login.....	54
11.3.4	Create New Plant.....	55
11.3.5	Add a Device.....	57
11.3.6	WLAN Configuration.....	60
11.3.7	Setting Parameters via Yinergy Cloud.....	63
11.3.7.1	Inverter Switch.....	65
11.3.7.2	Grid Parameter Settings.....	65
11.3.7.3	Inverter Settings.....	68
11.3.7.4	Battery Settings.....	78
11.3.7.5	Meter Settings.....	79
11.3.7.6	Work Mode Settings.....	80
11.3.7.7	Dry Contact Settings.....	81
11.3.7.8	Special Functions Settings.....	81
11.3.7.9	ARF Settings.....	82
11.3.8	Plant Interface.....	83
12	Decommissioning the Product.....	85
12.1	Disconnecting the Inverter from Voltage Sources.....	85
12.2	Dismantling the Inverter.....	88
13	Troubleshooting and Maintenance	89
13.1	Power off.....	89
13.2	Troubleshooting.....	89

13.3	Maintenance.....	97
13.3.1	Removing the Inverter.....	97
13.3.2	Scrap Inverter	98
13.3.3	Maintenance Routines	98
13.4	Recycling and Disposal.....	98
13.5	Service and Warranty.....	99
14	Technical Data.....	100

The safety information contained in this document must be followed at all times when operating the equipment.

NOTICE

- The inverter has been designed and tested in strict accordance with safety regulations. However, being an electrical equipment, it is crucial to adhere to the relevant safety instructions before any operation. Failure to operate the equipment properly may result in severe injuries or property damage. Please ensure you follow all safety guidelines diligently.

1.1 General Safety

NOTICE

- Due to product version upgrades or other reasons, the document content will be subject to periodic updates, unless there is a special agreement, the document content cannot replace the label on the product. All descriptions in the documentation are intended solely as guidelines for usage.
- Please carefully read this document to fully understand the product and precautions before installing the appliance.
- All operations of the equipment must be conducted by professional and qualified electrical technicians who are familiar with the relevant standards and safety specifications of the project location.
- When operating the inverter, it is essential to use insulating tools and wear personal protective equipment to ensure personal safety. Contact electronic devices requires wearing electrostatic gloves, electrostatic bracelets, anti-static clothing, etc. to protect the inverter from electrostatic damage.
- Any equipment damage or personal injury caused by failure to install, use and configure the inverter in accordance with the requirements of this document or the corresponding user manual is not the responsibility of the equipment manufacturer. For more information of product warranty, please visit the official website: <https://www.yinergy-solar.com/>.

1.2 PV String Safety



DANGER!

- Please use the DC terminal supplied with the box to connect the inverter DC cable. The use of other DC terminal can lead to serious consequences, and any resulting damage to the equipment will not be covered by the equipment manufacturer.



WARNING!

- Ensure that the PV modules and bracket system are well grounded.
- After the completing DC cable connection, please ensure that the cables are securely and correctly connected.
- Use a multi-meter to measure the positive and negative poles of the DC cable to verify correct polarity and no reverse connections. Ensure that the voltage is within the permissible range. Do not connect the same PV string to multiple inverters, otherwise it may cause damage to the inverter.

1.3 Inverter Safety



WARNING!

- Ensure that the voltage and frequency of the grid connection meet the inverter grid connection specifications.
- It is recommended to add protection devices such as circuit breakers or fuses on the AC side of the inverter, and the specifications of the protection devices should be greater than 1.25 times the rated current of the AC output of the inverter.
- The protective ground wire of the inverter must be securely connected to ensure that the impedance between the neutral wire and the ground wire is less than 10 Ω .
- Copper core cable is recommended for AC output cable, if aluminum wire is required, a copper aluminum transition terminal is required for wiring.
- In case a single inverter overloaded event, the inverter can be automatically restarted. If it happens multiple times, the inverter restart time will be extended, to restart the inverter promptly, you can restart the inverter immediately through the App.
- If the photovoltaic system is not equipped with batteries, do not use the BACK-UP function. Otherwise, the manufacturer shall not be liable for related risks.



DANGER!

- Avoid bearing any load on the bottom terminal of the inverter during installation to prevent terminal damage.
- After installation, ensure the labels and warning signs on the inverter are clearly visible, it is forbidden to cover, deface or damage them.

1.4 Battery Safety



WARNING!

- The battery used with the inverter must be approved by the inverter manufacturer. The lists of approved batteries can be obtained through the official website.
- Before equipment installation, carefully read the user manual corresponding to the battery to understand the products and precautions. Strictly follow the requirements outlined in the battery user manual.
- If the battery is fully discharged, ensure that you charge the battery following the guidelines specified in the corresponding model's battery user manual.
- Battery current may be affected by some factors such as temperature, humidity, weather conditions, etc., which could result in current limiting and affect the load capacity.
- When connecting the DC cable, use a multi-meter to verify correct polarity, and ensure that the voltage falls within the permissible range.
- Do not connect one battery pack to multiple inverters, as it may cause damage to the inverter.

1.5 Personal Requirements



NOTICE

- The personnel responsible for equipment installation and maintenance must receive comprehensive training, understand all necessary safety precautions, and be capable of performing all operations correctly.
- Installation, operation, maintenance, replacement of equipment or parts is permitted to be conducted by qualified professionals or trained personnel only.

2.1 System Description

System Overview

The inverter regulates and optimizes the energy flow in photovoltaic systems through an integrated energy management system. The electricity generated by the photovoltaic system can be used by the load, stored in the battery, and also exported to the grid.

2.2 Appearance

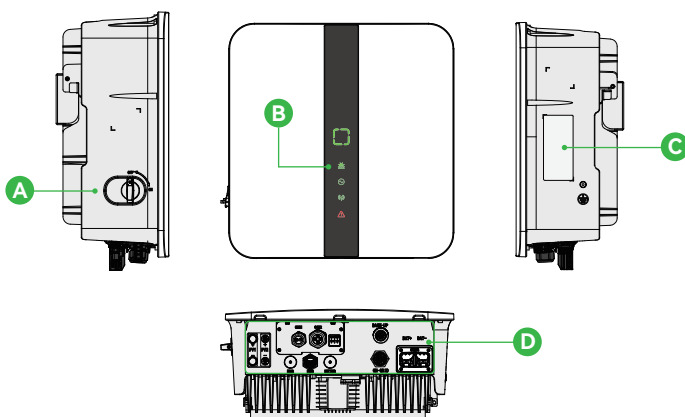

No.	Item	Description
A	DC Switch	Disconnect the DC circuit when necessary
B	LED Panel	Including indicators, indicate the status of inverter
C	Nameplate	Nameplate clearly identifies the device type, serial number, specific DC/AC parameters, certification, etc.
D	Electrical Connection Area	Including PV terminals, battery terminals, AC terminals, communication terminals, etc.

i NOTICE

- Supplementary information for HI-1P3K-L-Y1:
PV2+/- input ports are not used and will be fitted with waterproof sealing plugs during manufacturing. The sealing plugs can only be removed with the use of a tool and is not intended to be removed by the end user.

2.3 Supported Power Grid

The inverter supports the following power grid types. For the grid types with N lines, the N voltage to ground needs to be less than 10 V.

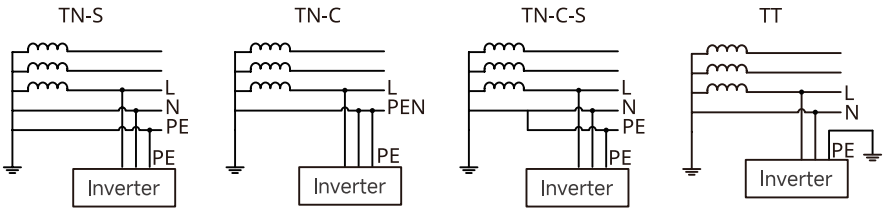



Figure 2-1 Power Grid

2.4 Symbols on the Label and Inverter

Symbol	Description
	Grounding point.
	Potential risks exist. Wear proper Personnel Protective Equipment before any operations.
	Delayed discharge. Wait 5 minutes after power off until the components are completely discharged.
	High-temperature hazard. Do not touch the product under operation to avoid being burnt.
	Do not dispose of the inverter as household waste. Discard the product in compliance with local laws and regulations, or send it back to the manufacturer.
	Read through the user manual before any operations.
	RCM Mark.
	CE mark.

2.5 Nameplate

 Product: Hybrid Inverter Model : HI-1P6K-L-Y1	
PV Input	Max.Input Voltage:550 Vd.c. MPPT Range:90-520 Vd.c. Max.Input Current:20/20 Ad.c. Max.Short-circuit Current:27/27 Ad.c.
Battery	Voltage Range:40-60 Vd.c. Max.Charge/Discharge Current:135 Ad.c. Type:Li-ion
On-grid	Output Nominal Voltage:230V,L/N/PE Nominal Operating Frequency:50 Hz Output Rated Power:6 kW Rated Output Apparent Power:6 KVA Max.Output Apparent Power:6.6 kVA Rated Output Current:26.1 A Max.Output Current:28.7 A Max.Input Apparent Power:10 kVA Max.Input Current:43.5 A
Back-up	Output Nominal Voltage:230V,L/N/PE Nominal Operating Frequency:50 Hz Output Rated Power:6 kW Max.Output Current:26.1 A Rated Output Apparent Power:6 kVA
Others	Power Factor: 0.8 leading to 0.8 lagging Operating Temperature:-25~+60 °C Enclosure:IP66 Protection Class:I OVC AC III /DC II Topology:Non-Isolated
DRM0 DRM1 DRM2 DRM3 DRM4 DRM5 DRM6 DRM7 DRM8 <input checked="" type="checkbox"/> <input type="checkbox"/> <input type="checkbox"/> <input type="checkbox"/> <input type="checkbox"/> <input type="checkbox"/> <input type="checkbox"/> <input type="checkbox"/> <input type="checkbox"/>	
	
S/N	<div style="border: 1px solid black; height: 30px; width: 100%;"></div>
Made in China Yinergy Digital Power Technology Co., Ltd. www.yinergy-solar.com Building 4&5, No.161, Yuancheng Road, Qiantang District, Hangzhou, 310018, Zhejiang, P.R.China	

No.	Description
A	YINERGY trademark, product type, and product model
B	Technical data
C	Safety symbols and certification marks
D	Serial number and contact information

Figure 2-2 Nameplate

2.6 Working Principle

The inverter unit converts DC into AC that meets the requirements of the power grid and feeds it into the power grid. The principle design of inverter is shown in the figure below:

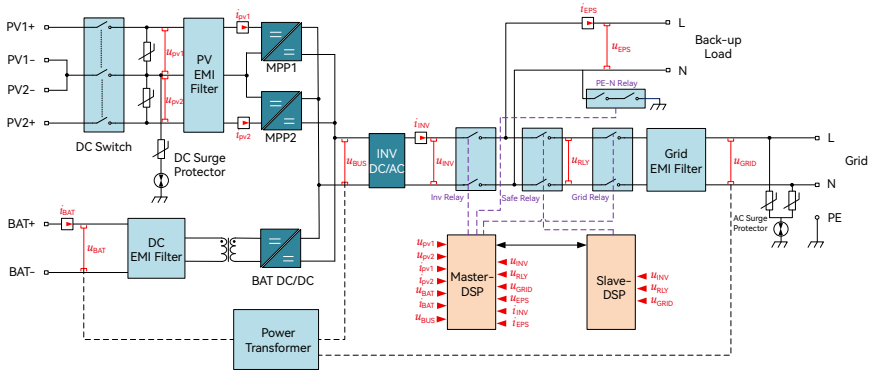
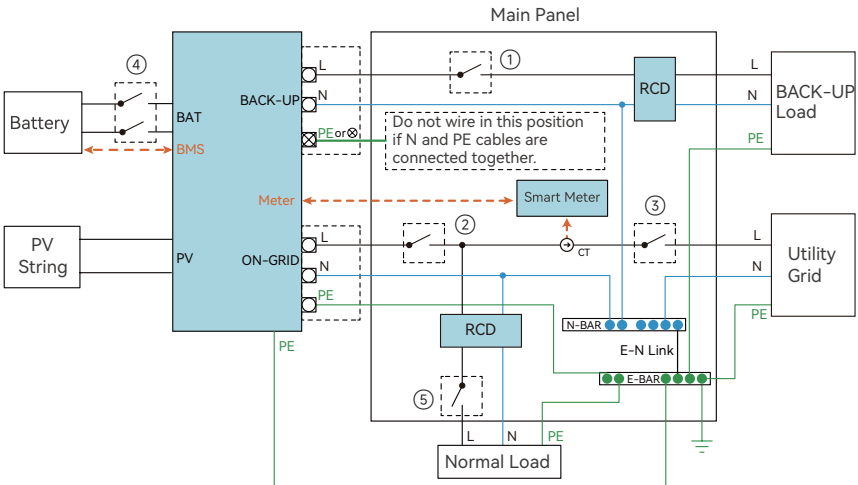

Figure 2-3 Circuit Diagram

NOTICE

- Supplementary information for HI-1P3K-L-Y1:
PV2+/- input ports are not used and will be fitted with waterproof sealing plugs during manufacturing. The sealing plugs can only be removed with the use of a tool and is not intended to be removed by the end user.

N and PE cables are wired together in the Main Panel



No.	Recommended Circuit Breaker Specifications
①	32 A / 230 V / 400 V AC breaker
②	≤ 63 A / 230 V / 400 V AC breaker
③	Depends on household loads and inverter capacity
④	3.0 / 3.6 / 4.0 / 5.0 / 6.0: 40A / 600 V DC breaker 5.0 / 6.0: 63 A / 600V DC breaker
⑤	Depends on loads

Figure 2-4 N and PE Cables Connection

NOTICE

- Below wirings are applicable to areas in Australia, New Zealand, and etc. For the BACK-UP function, the internal ground (GND) on the EPS side is floating. Please ensure that Neutral is bonded to PE in the distribution box, in accordance with local wiring regulations.

2.7 Interfaces and Functions

The product is equipped with the following interfaces and functions:

WiFi-Dongle

WiFi-Dongle is optional, which provides a user interface for configuring and monitoring the product. The WiFi-Dongle can connect to the Internet via WLAN. If a dongle is needed, please contact the dealer.

RS485 Interface

The product is equipped with several RS485 interfaces. Some RS485 interfaces are connected to RJ45 ports. Some RS485 interfaces are connected to terminal block.

RJ45-3 port: Connecting to the third-party monitor device. If you don't want to use WiFi-Dongle, the third-party monitor device can be used.

Terminal block 2: (Pin1 and Pin2) Connecting to the external smart meter. If the smart meter is chosen to replace the current transformer, the smart meter can connect to this RS485 interface.

RS485/CAN (Controller Area Network) Interface

The product is equipped with several RS485/CAN interfaces. The CAN interfaces and RS485 interfaces connected through one RJ45 ports.

RJ45-4 port: Connecting to the BMS (Battery Manage System) of the battery. If the communication interface of the BMS is CAN interface, the pins for CAN interface can be chosen to connect. If the communication interface of the BMS is RS485 interface, the pins for RS485 interface can be chosen to connect.

Modbus RTU

The product is equipped with a Modbus interface. If the third-party communication device also complies with Yinergy Modbus protocol, it can be connected to this product.

Export Active Power Control

The product is equipped with the export active power limit function, so as to meet the requirements of some national standards or grid standards for limiting the output power at the grid connection point. The export active power control solution measures the active power at the point where the customer's installation is connected to the distribution system (point of grid connection) and then uses this information to control the inverter's output active power in order to prevent the export active power to the distribution system from exceeding the agreed export capacity.

The product is delivered with the current transformers as standard. The current transformers can be used to measure the export active power. The communication of the current transformers can be connected to the product through RS485. And the current transformer also can be replaced by the smart meter.

The smart meter that can be used with this product must be approved by Yinergy. For more information about the smart meter, please contact the service.

Multifunction Relay

The product is equipped with two multifunction relays as standard. The multifunction relays can be configured for the operating mode used by a particular system. For more information, please contact Yinergy service.

Temperature Senser Interface

The product is equipped with one temperature senser interface. If the temperature of the battery need be monitored, the external senser can be connected.

Inverter Demand Response Modes (DRED)

The product shall detect and initiate a response to all supported demand response commands according to the standard **AS/NZS 4777.2**.

The product only supports the demand response mode DRM 0. The interaction with

demand response enabling device (DRED) can be connected to the terminal block 3.

Current Transformer Interface

The current transformers can be used to measure the export active power and control the export active power at the point of grid connection. The three current transformers can be connected to terminal block 4.

Back-up Function

The inverter is equipped with a back-up function which also called as an emergency power supply (EPS). The back-up function ensures that the inverter forms a three-phase back-up grid that uses energy from the battery and the PV system that is directly connected to the inverter to supply the critical load in the event of a utility grid failure.

In the event of a grid failure, the product disconnects from the grid. The product provides a standalone grid and the backup loads, which connect to EPS connector, continue to be supplied by the energy stored in the battery and the PV modules.

The charging of the battery is ensured by the existing PV system during back-up operation.

As soon as the utility grid is available again, the product will automatically connect to the grid and the loads are supplied with energy from the utility grid as needed.

Earth Fault Alarm

This product complies with IEC 62109-2 clause 13.9 for earth fault alarm monitoring. If an Earth Fault Alarm occurs, the red color LED indicator will light up. At the same time, the error code 160 and code 162 will be sent to the Yinergy Cloud.

Battery Energy Storage System (BESS) Earth Fault/Earth Leakage Detection

For all pre-assembled battery systems separated from earth (i.e. floating) or connected to earth via a resistor and operating at DVC-B or DVC-C, an earth fault alarm system shall be installed.

The alarm system shall include an audible signal activated in a location where an authorized person will be aware of the signal.

Earth fault detection systems, including any additional monitoring or alarm connections or devices, shall be in accordance with the manufacturer's requirements.

2.8 Working Mode

Economic Mode

NOTICE

- Economic models can only be used when local laws and regulations are met, such as whether the power grid is allowed to charge the battery or whether the battery is allowed to discharge and sell to the power grid. If not, do not use this mode.
- It is recommended to use economic mode in scenarios when the peak-valley electricity price varies a lot.

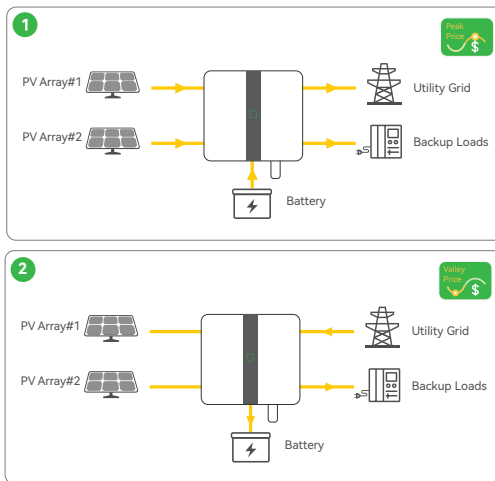

Figure 2-5 Economic Mode

In economic mode, the discharge and charging time of the battery should be preset according to the peak and valley electricity prices.

During peak electricity prices, the battery will discharge power to the load. Conversely, during valley electricity prices, the battery will be charged from the grid.

Self-Consumption Mode

NOTICE

- For solar power, consider self consumption mode in priority: the excess power charges the battery in day time; the battery supplies power to the load when there is no solar power generated at night. This will improve the self consumption rate and saves electricity costs.
- It is suitable for areas with high electricity prices and little or no solar power generation subsidies.

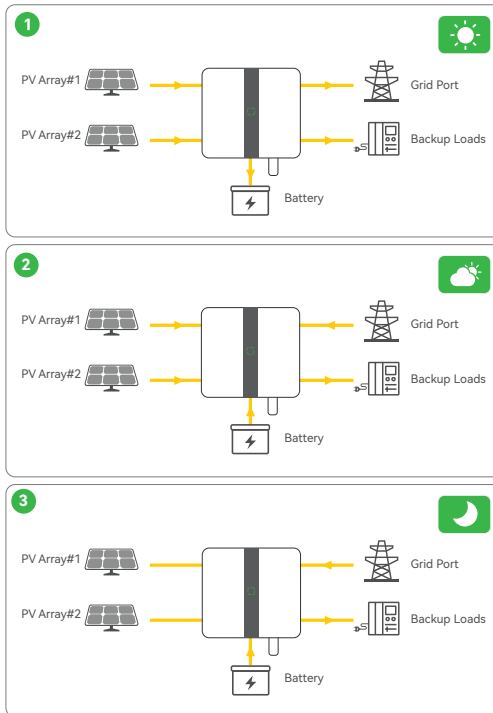

Figure 2-6 Self-Consumption Mode

In the self-consumption mode, solar power prioritizes supplying power to the load, with any excess power used for battery charging, then the remaining power will be feed back into the grid (or limited if necessary).

When there is no solar power generation at night, batteries are used to supply power to the load. Once the battery power is insufficient, the grid supplies power to the loads.

Back-up Mode

NOTICE

- In Back-up mode, you can set different battery SOC values for grid-tied and off-grid status. When the power grid is cut off, the inverter switches to off-grid mode, and the battery can discharge to supply power to the load to ensure that the BACK-UP load does not lose power; When the power grid is restored, the inverter switches to grid-tied mode. If the battery's SOC is lower than the set SOC, the battery can be charged by power grid.
- The purchase of electricity from the power grid to charge the battery must comply with local laws and regulations.
- Recommended for use in areas with unstable power grid.

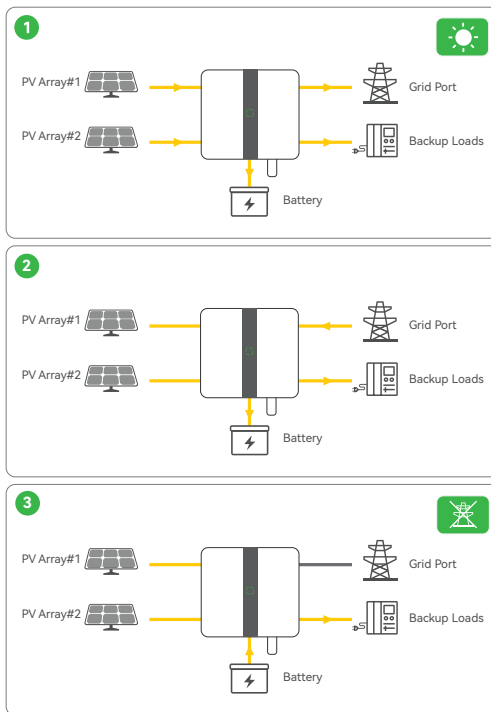

Figure 2-7 Back-up Mode

In the back-up mode, the battery is charged by both the PV system and the grid, and is always kept in a relatively high state of charge (SOC).

When the power generated by the PV system is sufficient, it charges the battery as priority, and the excess power charges the load, the remaining power will be sold to the grid. In case of grid abnormality, the inverter will switch to off-grid mode and the battery will supply power to the important load / backup loads. Since the battery power is insufficient, the grid supplies power to the loads.

Off-Grid Mode

NOTICE

- The PV energy storage system (ESS) is not suitable for powering life-sustaining medical devices. It cannot guarantee backup power in all circumstances.
- The hybrid inverter supports EPS with a switching time is less than 10ms. However, the EPS function may fail to start if the important load capacity exceeds the rated power of the inverter.

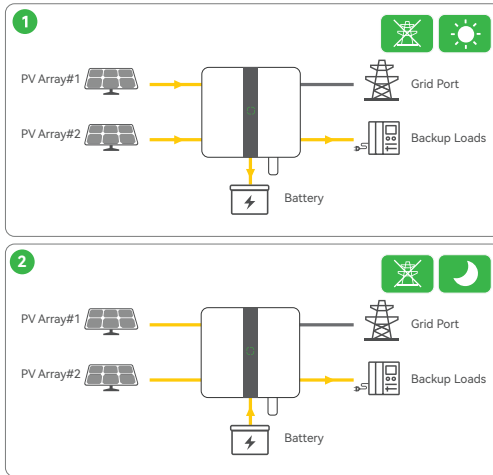

Figure 2-8 Off-Grid Mode

When the grid is off, system will automatically switch to EPS mode. In this mode, system supply emergency power from PV or battery to support the backup loads, and in this mode, battery is required to balance the power difference of loads and PV.

New PV + ESS

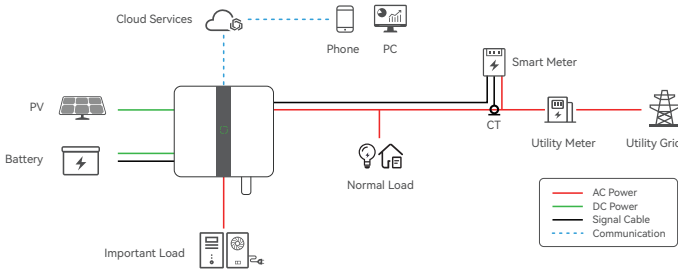

Figure 3-1 New PV + ESS

Retrofitting the Existing PV System

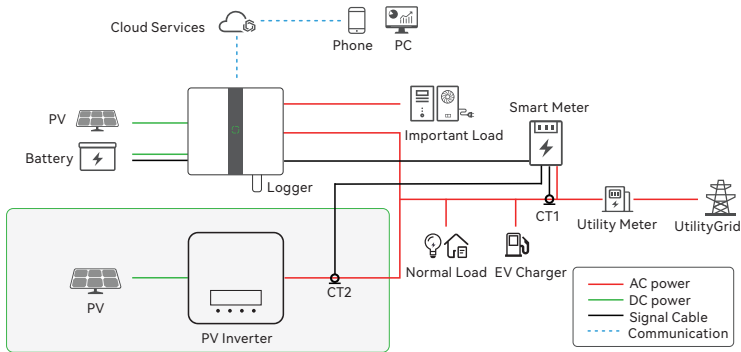

Figure 3-2 Retrofitting the Existing PV System

In this system, the Yinergy hybrid inverter can dynamically charge/discharge the battery based on the overall measurement data at the Smart Meter location and achieve self-consumption logic considering the operation condition of both it and the existing PV inverter. CT1 should be connected to the output port of the inverter. And the CT2 will collect the generation data of the existing PV inverter and present on Yinergy monitoring system.

If the inverter is not put into use immediately, the transportation and storage requirements needs to be met:

Transportation

- Observe the caution signs on the packaging of inverter before transportation.
- Pay attention to the weight of the inverter. Carry the inverters by one or two person(s). (Net weight of Single-Phase Hybrid Inverter: 27 kg)
- Wear protective gloves when carrying the equipment by hand to prevent injuries.
- When lifting up the inverter, hold the bottom position of the carton. Keep the inverter horizontal in case of falling down.

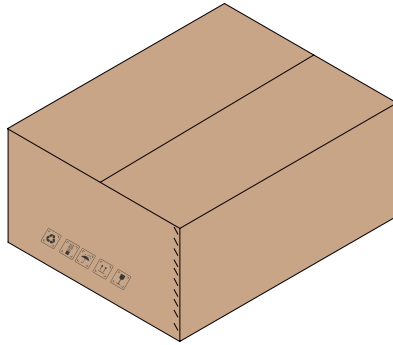

Figure 4-1 Caution Signs on the Package

Storage

- The inverter must be stored indoors.
- Do not remove the original packaging material and check the outer packaging material regularly.
- The storage temperature should be between $-40\text{ }^{\circ}\text{C}$ and $+70\text{ }^{\circ}\text{C}$. The relative humidity should be between 0%RH and 100%RH.
- Stack the inverter in accordance with the caution signs on the inverter carton to prevent their falling down and device damage. Do not place it upside down.

5.1 Selection of Installation Location

The installation location selected for the inverter is quite critical in the aspect of the guarantee of machine safety, service life and performance. It has the IP66 ingress protection, which allows it to be installed outdoor. The installation position shall be convenient for wiring connection, operation and maintenance.

5.2 Environment Requirement

- Do not install the equipment in a place near flammable, explosive, or corrosive materials.
- Do not install the equipment in a place that is easy to touch, especially within children's reach. High temperature exists when the equipment is working. Do not touch the surface to avoid burning.
- Avoid the water pipes and cables buried in the wall when drilling holes.
- Install the equipment in a sheltered place to avoid direct sunlight, rain, and snow. Build a sunshade if it is needed.
- The place to install the equipment shall be well-ventilated for heat radiation and large enough for operations.
- The equipment with a high ingress protection rating can be installed indoors or outdoors. The temperature and humidity at the installation site should be within the appropriate range.
- Install the equipment at a height that is convenient for operation and maintenance, electrical connections, and checking indicators and labels.
- The altitude to install the inverter shall be lower than the maximum working altitude (≤ 4000 m).
- Install the equipment away from electromagnetic interference.

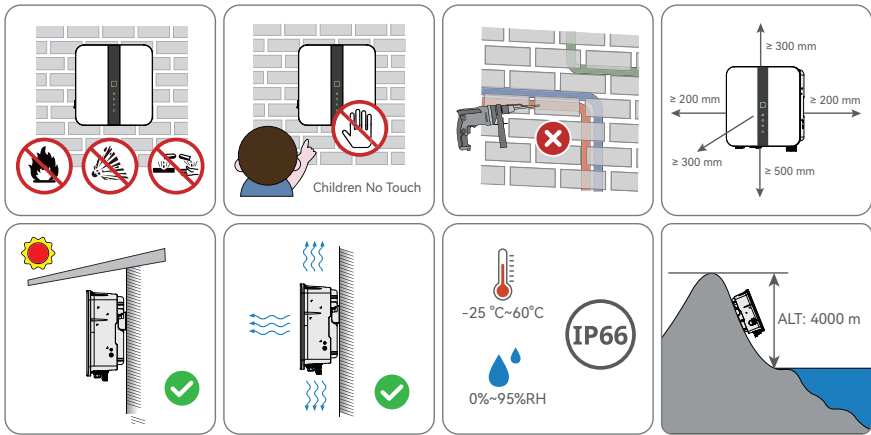

5.3 Installation Carrier Requirement

- The mounting structure must be non-flammable and fire resistance.
- Please ensure that the installation structure is solid enough to support the weight of inverter. The wall is required as a sturdy solid wall.
- When the equipment is running, it will emit vibration, please do not install it on a structure with poor sound insulation, so as to avoid disturbing the residents of the living area by the noise during the equipment working.

5.4 Installation Angle Requirement

- Install the inverter vertically or with a maximum back tilt of 15 degrees to facilitate heat dissipation.
- Do not install the inverter in forward tilted, excessive back tilted, side tilted, horizontal, or upside-down positions.

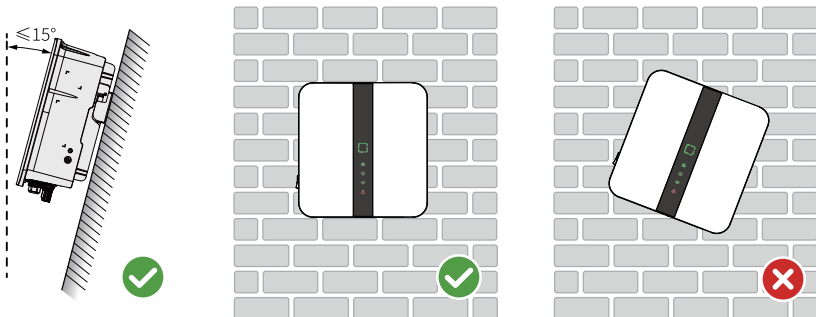

5.5 Tools Requirement

Installation tools include but are not limited to the following recommended ones. If necessary, use other auxiliary tools on site. The following tools must all comply with regulatory requirements.



5.6 Additionally Required Materials

Table 5-1 Additionally Required Wires

No.	Cable	Type	Outer Diameter	Cross Section
1	PV Cable	<ul style="list-style-type: none"> Outdoor multi-core copper wire cable Complying with ≥ 600 V and 30 A standard 	4.5~7.8 mm	4~6 mm ²
2	Battery Cable	Complying with 48 V and 125 A standard	9.5~12.5 mm	20~35 mm ²
3	Communication Cable	Shielded twisted pair	4.5~6 mm	2×(0.5~1.0) mm ²
		CAT 5E outdoor shielded network cable	4.5~6 mm	8×0.2 mm ²
4	AC Cable *	Grid	13~22 mm	6~10 mm ²
		Backup	10~12 mm	4~6 mm ²
5	Additional Grounding Cable *	Outdoor single-core copper wire cable	The same as that of the PE wire in the AC cable	

NOTICE

- If local regulations have other requirements for cables, set the cable specification according to the local regulations.

The factors that affect cable selection include rated current, cable type, routing mode, ambient temperature, and maximum expected line loss.

The cabling distance between the battery and the inverter should be less than 10 m. and within 5 m is recommended.

6.1 Unpacking

Before signing for the product, please check the following in detail:

- Check the outer packaging for any signs of damage, such as deformation, holes, cracks or other signs that may cause damage to the equipment inside the box, if any damage founded, do not open the package and contact your dealer.
- Unpacking the inverter according to the following figure.

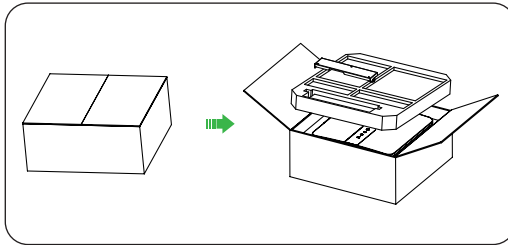

Figure 6-1 Unpacking the Inverter

- Verify that the inverter model is correct, if there is any discrepancy, do not open the package and contact your dealer.
- Check whether the type and quantity of deliverables are correct and whether the appearance is damaged. In case of damage, please contact your dealer.

6.2 Scope of Delivering

WARNING!

- For electrical connections, please use the terminal provided with the package, any damage to the device caused by the use of connectors of incompatible models will not be covered under the warranty.

Inverter

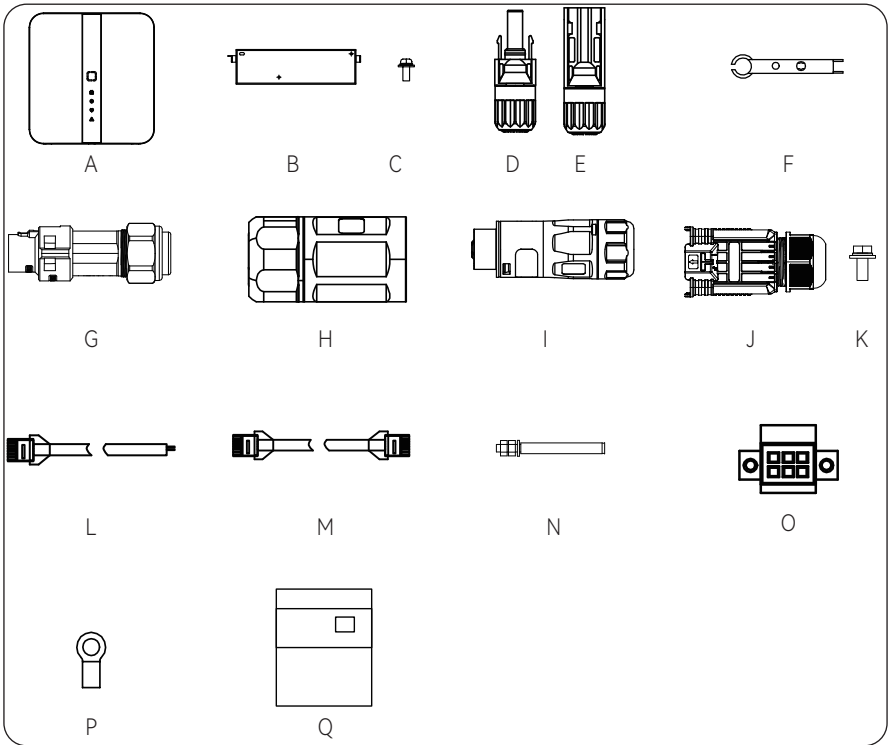

Table 6-1 Packing List of Inverter

No.	Item	Quantity
A	Inverter	1 pc
B	Bracket	1 pc
C	M4 Setscrew	2 pcs
D	Positive PV Connector	2 pcs
E	Negative PV Connector	2 pcs

No.	Item	Quantity
F	PV Disassembly Tool	2 pcs
G	Grid Connector	1 pc
H	RJ45 Connector	2 pcs
I	Backup Connector	1 pc
J	BAT Connector	1 pc
K	M8 Setscrew	2 pcs
L	Meter Network Cable	1 pc
M	Battery Network Cable	1 pc
N	M6 Expansion Screws	3 pcs
O	Plug Flange	1 pc
P	BAT Terminals	2 pcs
Q	Documents	/

Accessory Box

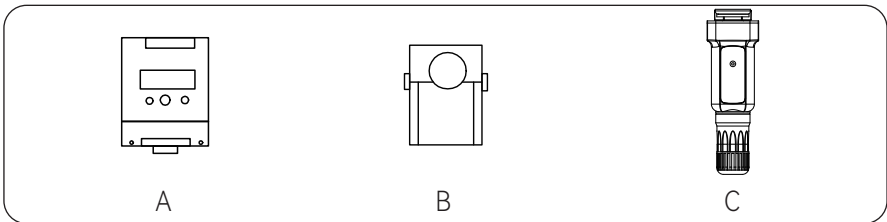

Table 6-2 Packing List of Accessory Box

No.	Item	Quantity
A	Smart Meter*	1 pc
B	CT	1 pc
C	WiFi-Dongle	1 pc

NOTICE

- *Smart Meter Infomation**
 Maker: Zhejiang Chint IoT Technology Co., Ltd.;
 Model: DDSU666-Q;
 Current Transductor: NCTK-16;

WARNING!

- When carrying out transportation, turnover, installation and other operations, adhere to the laws and regulations and relevant standards of the country and region where it is located.
- Do not use the wiring terminals and ports at the bottom to support any weight of the inverter.
- Before installation, the inverter needs to be transported to the installation site. In order to avoid personal injury or equipment damage during the handling, please pay attention to the following.
- Please follow the weight guidelines of the equipment and assign appropriate personnel to avoid the equipment exceeding the weight range that the human body can carry, thereby preventing injuries the personnel.
- Please wear safety gloves to avoid injuries.
- Please ensure that the equipment is balanced during handling to avoid falling.

NOTICE

- When drilling holes, avoid the water pipes and power cables buried in the wall.
- When drilling holes, wear goggles and dust masks to avoid dust entering your respiratory tract or getting into your eyes.
- Prepare an DC switch lock suitable for the lock hole diameter (Ø5 mm).
- Prepare an anti-theft lock suitable for the lock hole diameter (Ø8 mm).

7.1 Dimensions of Mounting

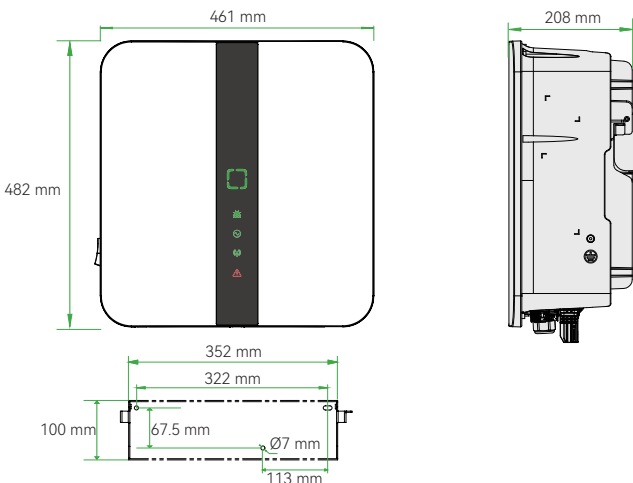

Figure 7-1 Dimensions

7.2 Installation Procedures

Step 1: Align the bracket horizontally on the wall and mark the position of the drill holes.

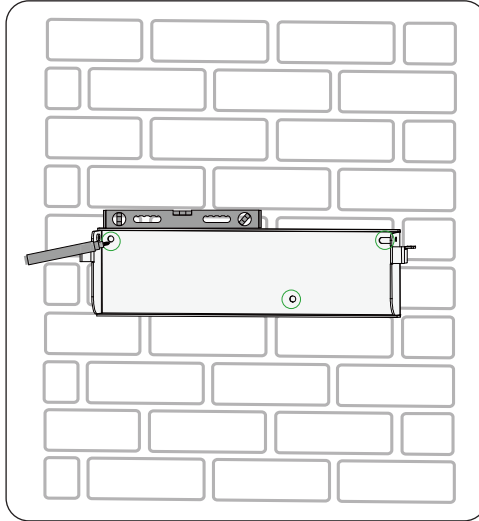

Figure 7-2 Marking Holes

Step 2: Set the bracket aside and drill holes with $\varnothing 8$ drill bit. The depth of the holes should be between 65-75 mm.

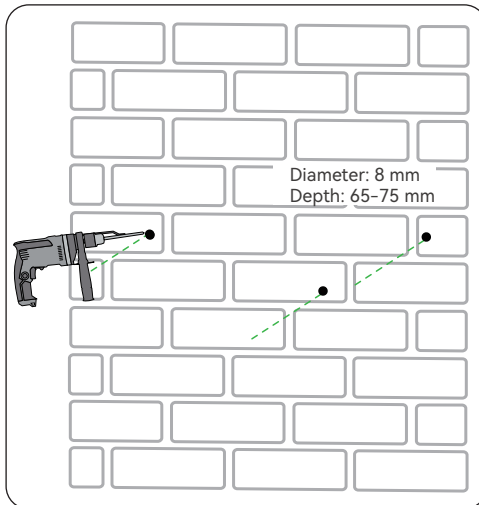

Figure 7-3 Drilling Holes

Step 3: Knock the expansion screws into the holes and secure the bracket to the wall with screws by torque wrench.

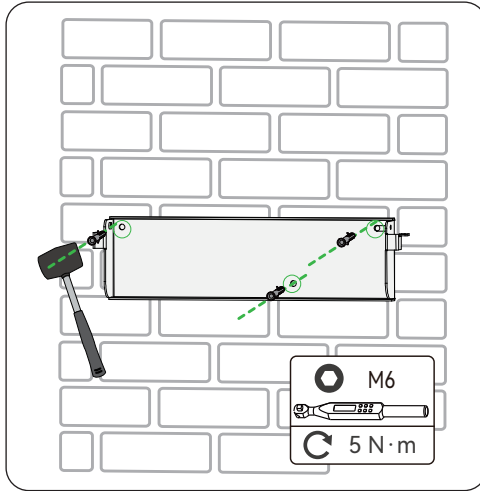

Figure 7-4 Insert Screws

Step 4: Lift the inverter by the handles and hang it on the bracket. The buckle on the bracket must be hooked into the keyways of the inverter. And then remove the handles.

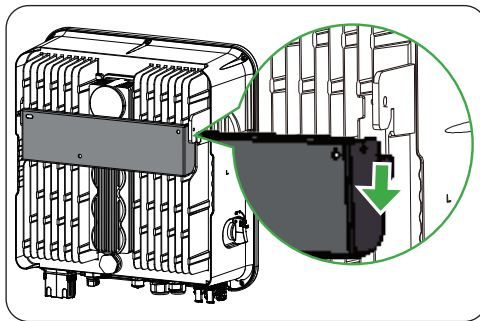

Figure 7-5 Hang the Inverter

Step 5: Secure the inverter to the bracket with M4 screw.

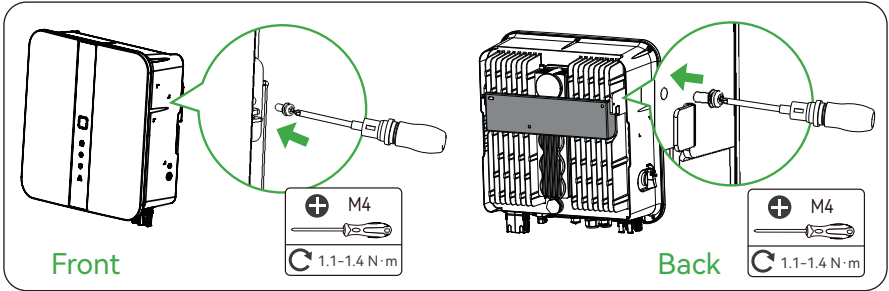

Figure 7-6 Secure the Inverter

DANGER!

- All operations, cables and component specifications used in the electrical connection process must comply with local laws and regulations.
- Before making the electrical connection, please disconnect the DC switch and AC output switch of the inverter to ensure that the equipment is powered off. It is strictly forbidden to operate with electricity, to avoid risks of electric shock.
- Same kind of cables should be tied together and keep them separate from different types of cables, it is forbidden to entangle or cross each other.
- If the cable is subjected to excessive tension, it may cause poor wiring, please reserve a certain length of the cable when wiring, and then connect it to the inverter wiring port.
- When crimping the terminal block, please ensure that the cable conductor part is in full contact with the terminal block. Do not crimp the cable insulation skin together with the terminal block to prevent unreliable connections, equipment malfunction, or heat generation that could lead to damage to the inverter's terminal block.

NOTICE

- When making electrical connections, wear personal protective equipment such as safety shoes, protective gloves, and insulating gloves as required.
- Only professionals are allowed to perform electrical connection-related operations.
- The cable colors in the graphics in this article are for reference only. Specific cable specifications must comply with local regulatory requirements.

8.1 Terminals of Inverter

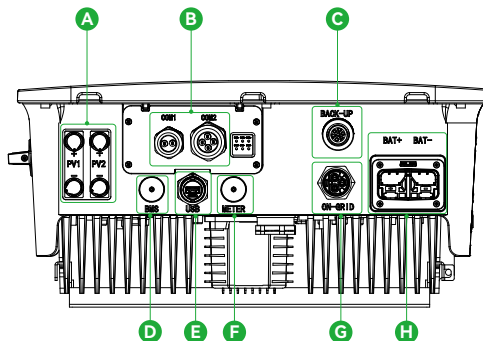

No.	Item	No.	Item
A	PV Connection Terminal	E	USB Terminal
B	Communication Terminal	F	Meter Terminal
C	Back-up Terminal	G	Grid Connection Terminal
D	BMS Terminal	H	Battery Connection Terminal

Figure 8-1 Terminals of Inverter

i NOTICE

- Supplementary information for HI-1P3K-L-Y1:
PV2+/- input ports are not used and will be fitted with waterproof sealing plugs during manufacturing. The sealing plugs can only be removed with the use of a tool and is not intended to be removed by the end user.

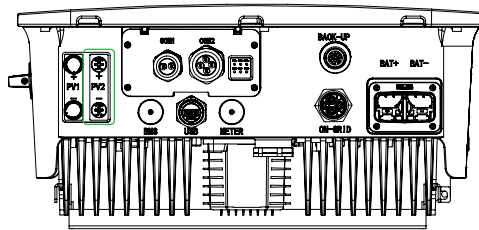

8.2 Grounding Connection

The inverter must be grounded reliably. The connection point has been labeled with the following label: We recommend that the inverter is earthed to a nearby ground point.

! WARNING!

- The protective ground of the chassis shell cannot replace the protective ground wire of the AC output port. Ensure that both protective ground wires are reliably connected when wiring.
- When multiple inverters are used, ensure that the protective grounding points of all inverter chassis housings are equipotential connected.
- Please use your own protective ground wire, recommended specifications:
Outdoor single core copper wire. Conductor cross-sectional area: 4~6 mm².

Step 1: Strip the insulation of conductor by wire stripper. Stripping length of 4-6 mm² wire is L1+2 mm.

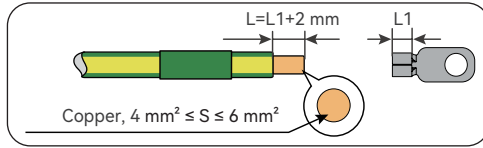

Figure 8-2 Stripping the PE Cable

Step 2: Pull the heat-shrink tubing over the PE cable and insert the stripped section into the OT terminal.

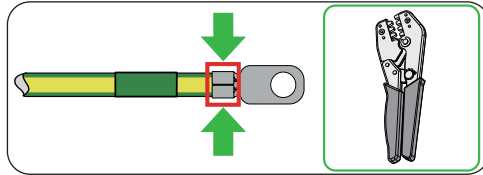

Figure 8-3 Crimping the Cable

Step 3: Use a heat gun to shrink it so that it can be firmly contacted with the terminal.

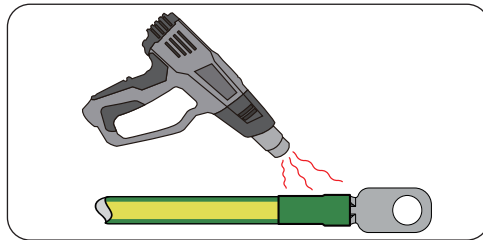

Figure 8-4 Shrinking the Tubing

Step 4: Connect the PE cable to the inverter and secure it with the original screw (Torque: 1.5~2 N·m).

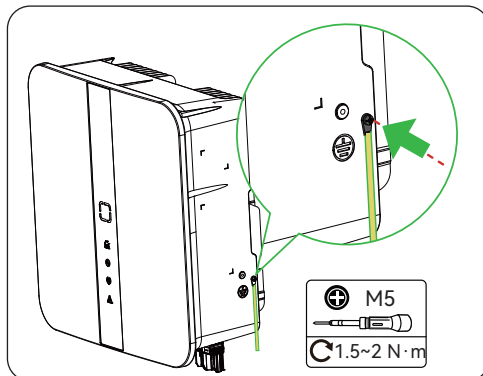

Figure 8-5 Securing the PE Cable

8.3 AC Connection



DANGER!

- Wire AC terminal must be wired even if off-grid load is not connected. Make sure the energized part cannot be touched, or electrical shock may be caused by high voltage, resulting in serious personal injury or death.



WARNING!

- It is prohibited to connect loads between the inverter and the AC switch directly connected to the inverter.
- In order to ensure that the inverter and the grid can be safely disconnected from the grid in the event of an abnormal situation, please connect the AC breaker on the AC side of the inverter. Multiple inverters cannot be connected to one AC breaker. Please choose the appropriate AC breaker according to local regulations.
- The inverter integrates a residual current monitoring unit, and when the inverter detects a leakage current greater than the allowable value, it will quickly disconnect from the grid.
- When the inverter is powered on, the BACK-UP AC port is live, if you need to perform maintenance on the BACK-UP load, please make sure the BACK-UP load circuit breaker is disconnected or the inverter is powered down, otherwise it may cause electric shock.



WARNING!

- Ensure that the AC wire exactly matches "L" and "N", and grounding ports of the AC terminal when wiring. The inverter may be damaged if the cables are connected to the wrong terminal.
 - Please ensure that the wire core is fully inserted into the terminal hole and is not exposed.
 - Make sure the cable connections are tight to prevent overheating of the terminal block during device operation, which could lead to device damage.
 - When connecting AC cables, it is recommended to connect the BACK-UP cable first and then the ON-GRID cable.
- » Choose whether to install RCD equipment according to local laws and regulations. The inverter can be externally connected with Type A RCD (residual current monitoring device) for protection when the DC component of the leakage current exceeds the limit.
- » RCD reference specification is 30 mA.

Off Grid

Step 1: Prepare a EPS cable (three-core copper wire) and strip the insulation of the EPS as below. Remove the cable padding inside the insulation.

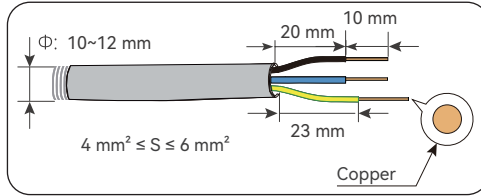

Figure 8-6 Stripping the Cable

Step 2: Disassemble the AC connector as below. Remove rubber plugs based on the actual wire diameter.

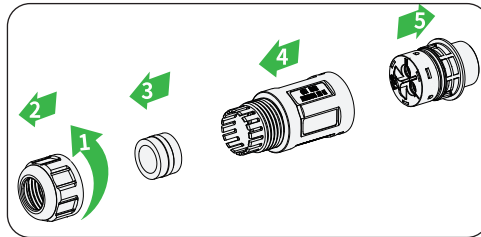

Figure 8-7 Disassembling the AC Connector

Step 3: Insert the crimped conductors L, N, and grounding conductor into the terminal block according to the labeling and tighten the terminal block screws.

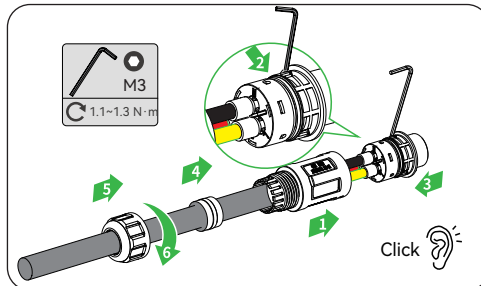

Figure 8-8 Assembling the AC Connector

Step 4: Remove the AC terminal caps and plug the assembled AC connectors into Grid terminal.

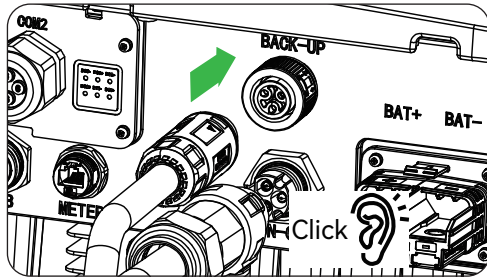

Figure 8-9 Installing the AC Connector to Inverter

On Grid

Step 1: Prepare a Grid cable (three-core copper wire) and strip the insulation of the Grid as below. Remove the cable padding inside the insulation.

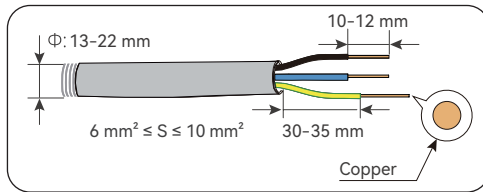

Figure 8-10 Stripping the Cable

Step 2: Disassemble the AC connector as below. Remove rubber plugs based on the actual wire diameter.

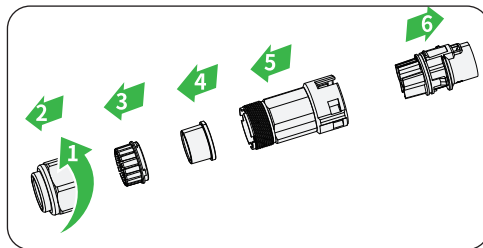

Figure 8-11 Disassembling the AC Connector

Step 3: Insert the crimped conductors L, N, and grounding conductor into the terminal block according to the labeling and tighten the terminal block screws.

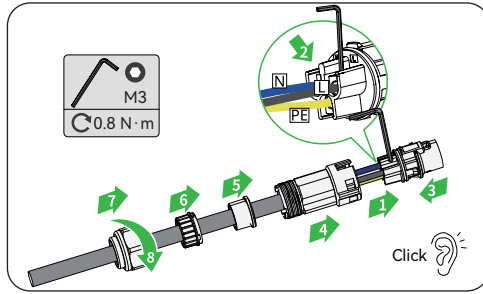

Figure 8-12 Assembling the AC Connector

Step 4: Remove the AC terminal caps and plug the assembled AC connectors into Grid terminal.

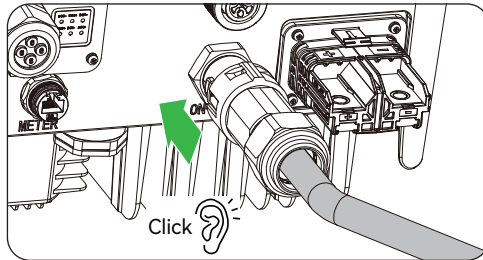

Figure 8-13 Installing the AC Connector to Inverter

8.4 PV Connection



DANGER!

- Do not connect the same PV string to multiple inverters, as it may cause damage.
- Before connecting the PV string to the inverter, please confirm the following information, otherwise it may cause permanent damage to the inverter, and in severe cases, it may cause fire, and lead to harm to personnel and property.
- Please make sure that the maximum short-circuit current and maximum input voltage of each MPPT are within the allowable range of the inverter.
- Make sure that the connection polarity of the PV string is correct.



WARNING!

- The PV string output does not support grounding, before connecting the PV string to the inverter, please ensure that the minimum insulation resistance of the PV string to ground meets the minimum insulation resistance.
- After the DC cable connection is completed, please ensure that is tight.
- Use a multimeter to measure the positive and negative poles of the DC cable to ensure that the positive and negative poles are correct and that there are no reverse connection. And ensure the voltage is within the permissible range.

Step 1: Strip approx. 7~8 mm of the cable insulation.

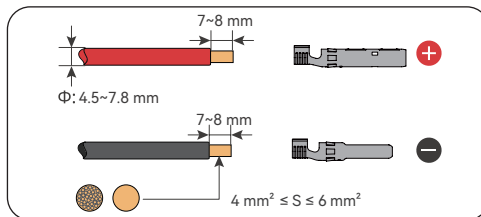

Figure 8-14 Stripping the PV Cable

Step 2: Insert the stripped cable into the PV pin contact. Ensure that the stripped cable and the PV pin contact are of the same polarity. Crimp it with crimping tool for PV terminal.

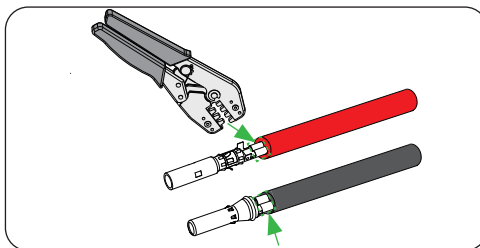

Figure 8-15 Inserting the PV PIN Contact and Crimping the Terminal

Step 3: Thread the PV cable through swivel nut and insert the cable into the PV connector until a "Click" is heard. Gently pull the cable backward to ensure firm connection. Tighten the swivel nut clockwise. Verify that the PV connectors have the correct polarity before connection.

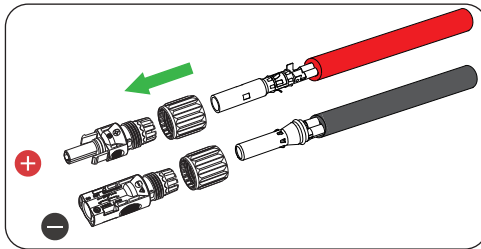

Figure 8-16 Threading the PV Cable

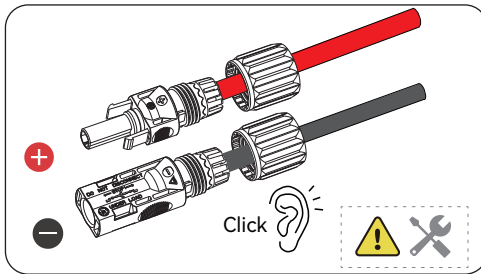

Figure 8-17 Securing the PV Cable

Step 4: Use a multimeter to measure the positive and negative voltage of the assembled PV connectors. Make sure the open circuit voltage does not exceed the input limit of 550 V.

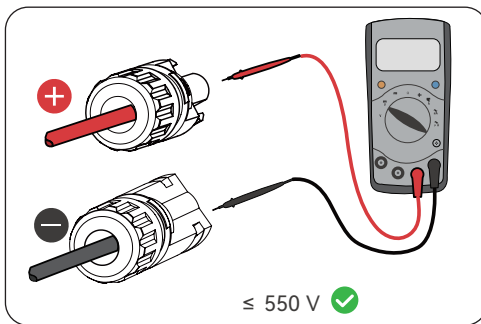

Figure 8-18 Measuring the Voltage of PV Connectors

Step 5: Remove the PV terminals caps and connect the assembled PV connectors to corresponding terminals until there is an audible "Click". The PV+ on the string side must be connected to the PV+ on the inverter side, and the PV- on the string side must be connected to the PV- on the inverter side.

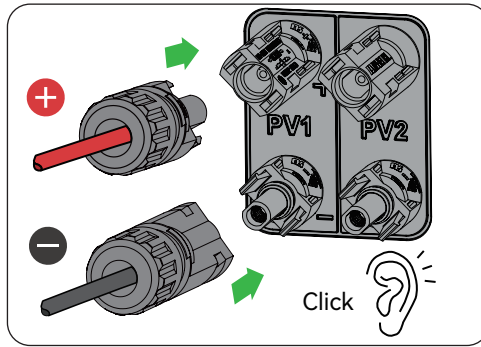

Figure 8-19 Connecting the PV Cable

i NOTICE

- Below wirings are applicable to areas in Australia, New Zealand, and etc. For the BACK-UP function, the internal ground (GND) on the EPS side is floating. Please ensure that Neutral is bonded to PE in the distribution box, in accordance with local wiring regulations.

8.5 Battery Connection

! DANGER!

- The battery used with the inverter needs to be approved by the inverter manufacturer. The lists of approved batteries can be obtained through the official website.
- Before connecting the PV string to the inverter, please confirm the following information, otherwise it may cause permanent damage to the inverter, and in severe cases, it may cause fire, and lead to harm to personnel and property.
- When the inverter is running, it is prohibited to connect and disconnect the battery cable, as illegal operation may cause the risk of electric shock.
- Do not connect the same battery pack to multiple inverters, as this may cause damage to the inverter.
- When connecting the battery cable, use an insulating tool to prevent accidental electric shock or short circuit of the battery.
- Please make sure that the battery open circuit voltage is within the allowable range of the inverter.
- A DC switch is required between the inverter and the battery.

WARNING!

- After completing the DC cable connection, please ensure that the cable connection is tight.
- Use a multimeter to measure the positive and negative poles of the DC cable to ensure that the positive and negative poles are correct and that there are no reverse connection. And ensure the voltage is within the permissible range.

Step 1: Strip approx. $L1+2$ mm of the cable insulation.

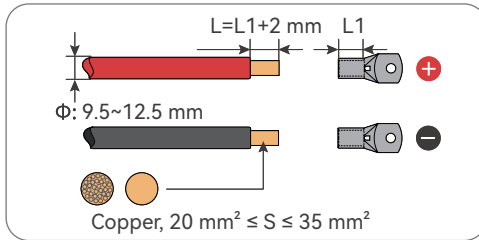

Figure 8-20 Stripping the Battery Cable

Step 2: Disassemble the connector.

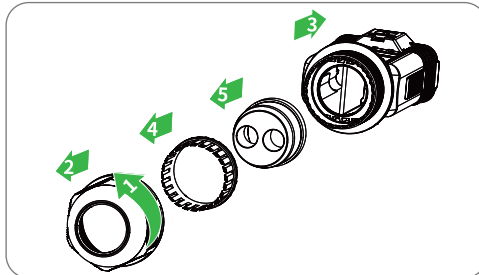

Figure 8-21 Disassemble the Connector

Step 3: Carefully insert the stripped wire with twisted litz wires all the way in. The litz wire ends have to be visible in the spring.

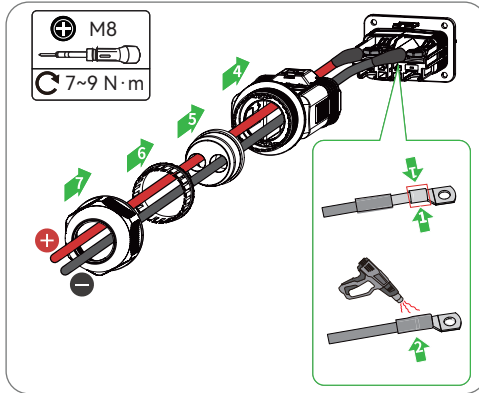

Figure 8-22 Insert the Wire

Step 4: Connect the assembled battery connectors to corresponding terminals.

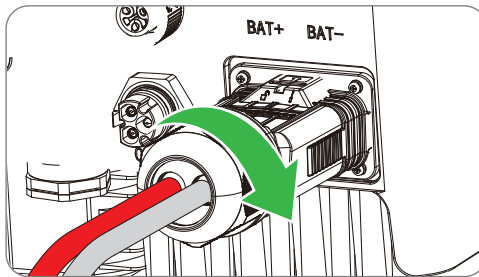

Figure 8-23 Connecting the Battery Connector

8.6 Communication Connection

Make sure that the communication device is connected to the right COM port. Route the communication cable far away from any interference source or power cable to prevent the signal from being influenced.

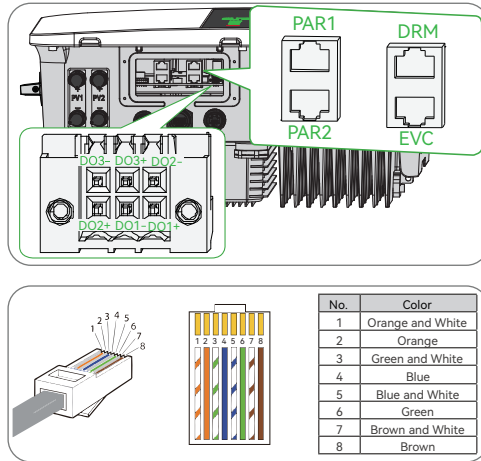

Figure 8-24 Terminals and PINs

Table 8-1 Communication Connections PIN

Terminal	Connector	Color	PIN No.	PIN
COM1	PAR1 / PAR2	Orange and White	1	485B
		Orange	2	485A
		Green and White	3	NC
		Blue	4	NC
		Blue and White	5	NC
		Green	6	NC
		Brown and White	7	CANH
		Brown	8	CANL

Terminal	Connector	Color	PIN No.	PIN
COM2	DRM	Orange and White	1	DRM1/5
		Orange	2	DRM2/6
		Green and White	3	DRM3/7
		Blue	4	DRM4/8
		Blue and White	5	REFGEN
		Green	6	COM/DRM0
		Brown and White	7	NC
		Brown	8	NC
	EVC	Orange and White	1	485_A
		Orange	2	485_B
		Green and White	3	FB_CTR_B
		Blue	4	FB_CTR_A
		Blue and White	5	NC
		Green	6	NC
		Brown and White	7	NC
		Brown	8	NC
/	Quick-Connect Terminal	/	1	DO3-
			2	DO3+
			3	DO2-
			4	DO2+
			5	DO1-
			6	DO1+

Step 1: Cut the communication cable as needed. Use wire strippers to strip the outer jacket of the cable to expose the inner wires.

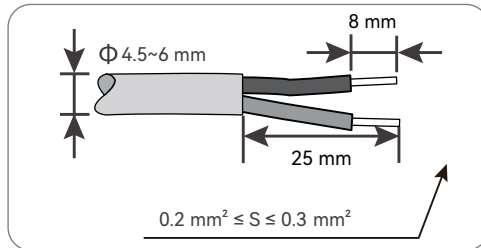

Figure 8-25 Stripping the COM Cable

Step 2: Anti-clockwise loosen the swivel nut and pull out the sealing plugs. Keep them still in the cable support sleeve if you choose not to connect the cable. Thread the cable through the swivel nut, cable support sleeve, and connector enclosure in sequence.

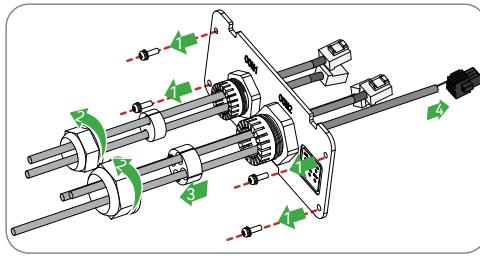

Figure 8-26 Inserting the Wires

Step 3: Secure the assembled connector on COM terminal.

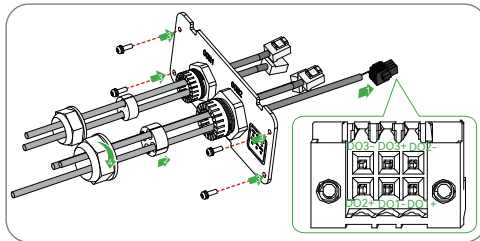

Figure 8-27 Securing the Connector

DRM Connection

According to AS/NZS 4777.2, the inverter needs to support the function of demand response mode (DRM). With the use of an external control box, active or reactive power regulation can be realized in a timely and fast manner, and the inverter can be operated stably during the process of regulation.

DRM 0 is available now.

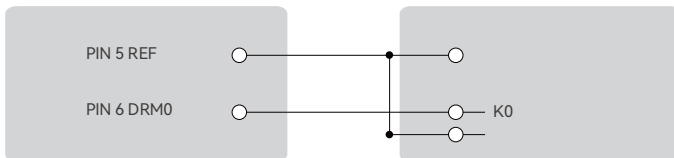

Table 8-2 DRM Operation

DRM Command	Switch	Function
DRM_MODE_0	K0	Power off

8.7 BMS, Smart Meter and CT Connection

Connecting the Battery BMS Communication and Meter Communication cables.

i NOTICE

- Each inverter needs to be connected to one Meter independently. Do not connect multiple inverters to the same Meter.
- Confirm the following items for a proper use of the Meter and CT:
 - » Ensure that CT is connected to L.
 - » Connect CT according to the pointing direction of the meter. It will display CT reverse fault on the inverter if it is the opposite direction.

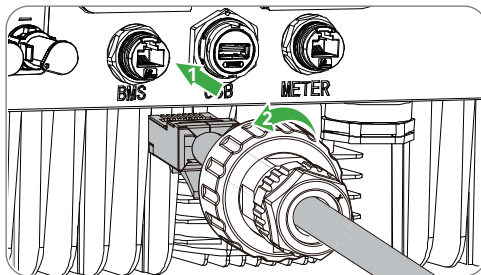

Figure 8-28 BMS Connection

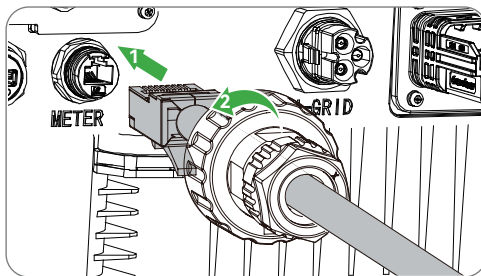

Figure 8-29 Meter Connection

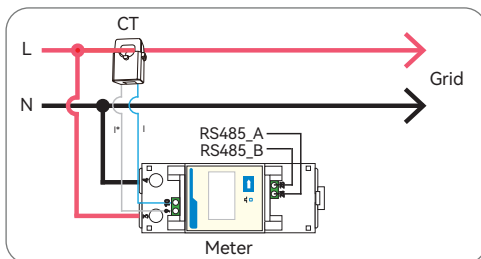

Figure 8-30 CT Connection

i NOTICE

- CT's arrow pointing to grid.

Table 8-3 PINs of BMS and Meter

Terminal	Connector	PIN No.	PIN
BMS	RJ45	1	TEMP+
		2	NC
		3	TEMP-
		4	CAN_H
		5	CAN_L
		6	NC
		7	RS485_A
		8	RS485_B
Meter	RJ45	1	NC
		2	NC
		3	NC
		4	485A
		5	485B
		6	NC
		7	NC
		8	NC

9.1 Check Before Power-on

Table 9-1 Checklist Before Power-on

Serial	Checklist
1	The inverter installed firmly that easily for operation and maintenance.
2	All lines, including PE, PV, Battery, AC and communication, are connected correctly and firmly.
3	The cable bundling complies with the wiring requirements, is properly distributed, and free from damage.
4	Ensure that a waterproof cover is installed for unused wire holes.
5	Ensure that the used wire holes have been sealed.
6	Verify that the voltage and frequency of installed location meet the grid-tied requirement.

9.2 Powering on the System

Before turning on the AC switch between the inverter and the grid, use a multimeter to check that the AC voltage is within the allowed range.

Step 1: Turn on the AC circuit breaker on the ON-GRID side of the inverter.

Step 2: Turn on the AC circuit breaker on the BACK-UP side of the inverter.

Step 3: Turn on the energy storage circuit breaker between the inverter and the battery.

Step 4: Turn on the DC switch of the inverter.

NOTICE

- Please set the inverter parameters first via Yinergy Cloud APP to ensure its normal operation. For details, please refer to [9.4 Setting Parameters via Yinergy Cloud](#).

Step 5: Send a system check command on the APP (optional).

Step 6: Observe the LEDs to check the inverter operating status.

9.3 Operation of Lockable DC Switch

The lockable DC switch includes 3 states: ON, OFF, and OFF + Lock. The DC switch is in the OFF state by default.

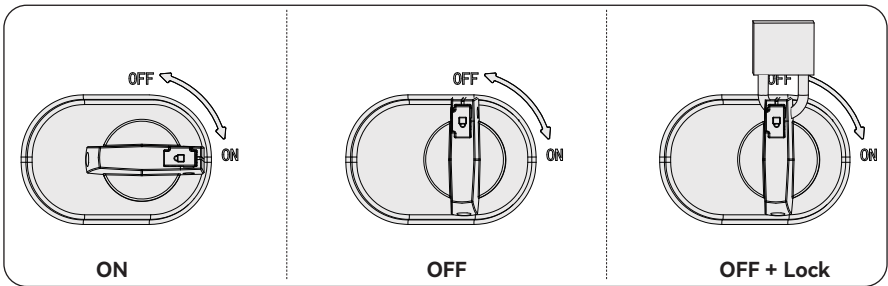

Figure 9-1 States of Lockable DC Switch

Turn on DC Switch

Turn on DC switch from OFF state to ON state

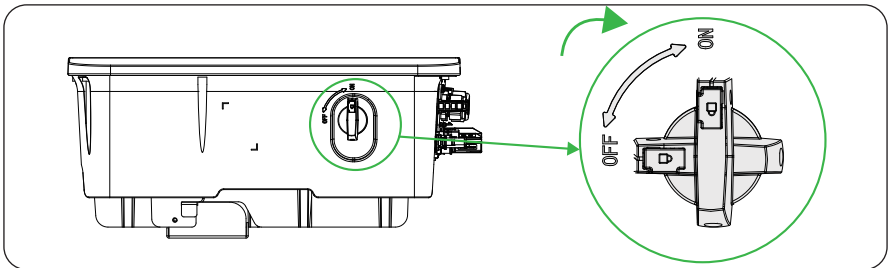

Figure 9-2 Turn on DC Switch

Turn off DC switch

Rotate DC switch from ON state to OFF state.

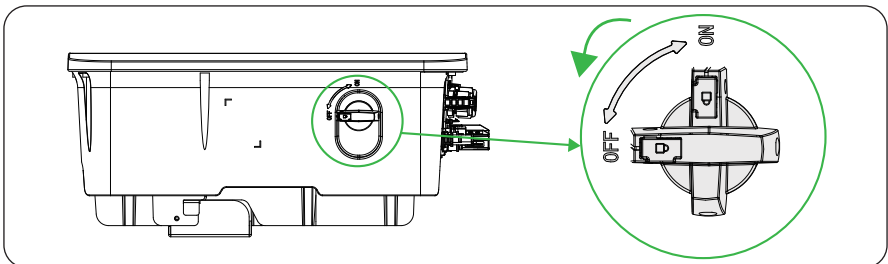

Figure 9-3 Turn off DC Switch

Lock DC switch

When DC switch is in the OFF state, press the buckle and add a lock to the switch, and hearing a "click" sound indicates that it is locked.

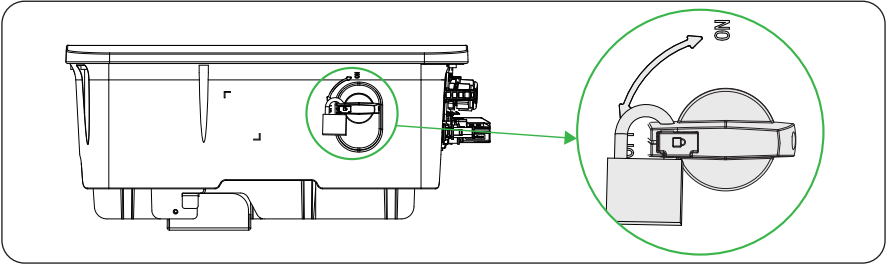

Figure 9-4 Lock DC Switch

Unlock DC switch

Remove a lock.

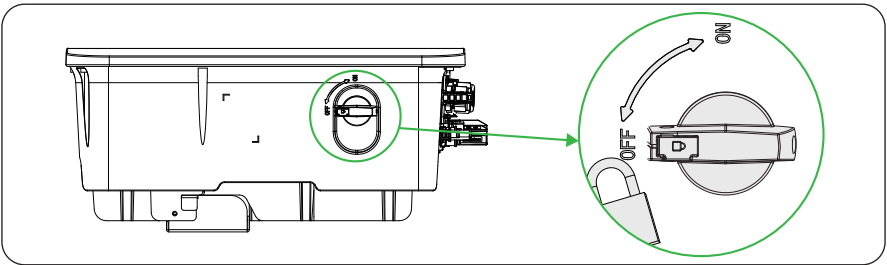

Figure 9-5 Unlock DC Switch

i NOTICE

- The lock needs to be prepared by yourself.

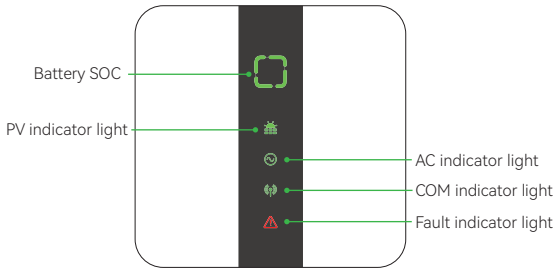

Figure 10-1 LED Panel

Table 10-1 LED Description























Item	Status	Description
 PV		Always on PV is generating power
		Blink 1 PV power is low ($\leq 30\%$ rated power)
		Off PV is not working
 AC		Always on Grid is active and connected
		Blink 1 Grid is disconnected but EPS is on
		Off Grid is disconnected and EPS is off
 COM		Always on Both BMS and meter communication are OK
		Blink 1 Communication of BMS is OK; meter fails
		Blink 2 Communication of meter is OK; BMS fails
 FAULT		Always on A fault has occurred
		Blink 1 RCM or IRD fault
		Off No fault

Table 10-2 Definition of Keys

Item	Status	Description	
 SOC		Always on	Battery SOC is 75%~100%
		3/4 on	Battery SOC is 50%~75%
		2/4 on	Battery SOC is 25%~50%
		1/4 on	Battery SOC is 10%~25%
		1/4 blink 1	Battery SOC is below 10%
		Full off	Battery is disconnected / not active

 **NOTICE**

- Blink 1 means on for 0.5 s and then off for 0.5 s, blink 2 means on for 0.5 s and then off for 1 s.

11.1 Introduction of Yinergy Cloud

Yinergy Cloud provides customers with a platform that can monitor inverter data and set it remotely. You can log in to your user account at any time through a personal computer, IOS or Android device to view real-time monitoring data or historical data, and perform remote settings as needed.

11.2 Operation on Yinergy Cloud Web

Open a browser and enter <https://yinergy.eslink.com/> to complete registration, login, adding plant and other operations according to the user guide.

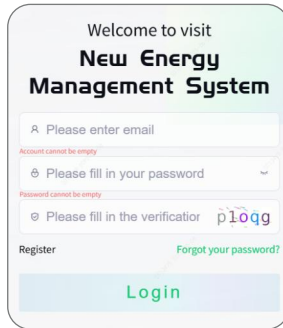

Welcome to visit
New Energy Management System

Please enter email
Account cannot be empty

Please fill in your password
Password cannot be empty

Please fill in the verification 

Register [Forgot your password?](#)

Login

Figure 11-1 Yinergy Cloud Web

11.3 Operation on Yinergy Cloud APP

11.3.1 Downloading and Installing APP

Scan the QR code below to download Yinergy Cloud APP. Or you can search **Yinergy** in App Store or Google Play to download it.



Android & IOS

Figure 11-2 QR Code

11.3.2 Registration

Step 1: Click **Register account** on the homepage.

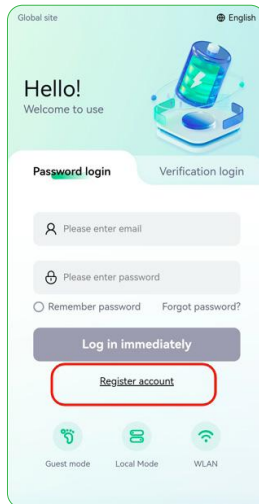

Figure 11-3 Register Account

Step 2: Select **Global site** and select **Organizational User** to register as an organizational user.

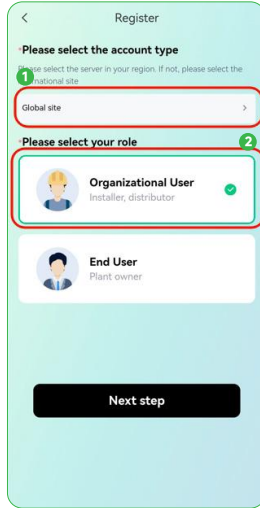

Figure 11-4 Select Organizational User

i NOTICE

- Account types are divided into End Users (plant owners) and Organizational Users (dealers/installers).
- End users can check some information about the power stations and devices.
- Organizational users can assist end users in creating power stations, managing installed/operating power stations, devices, as well as managing users and organizations.

Step 3: Fill in the registration information.

Figure 11-5 Register Organizational User

Table 11-1 Organizational User Configuration

Item	Explanation
*Country (region)	Select the country (region) where the organization is located.
Parent organization code	<ul style="list-style-type: none"> Enter the parent organization code to indicate that the newly created organization is a subsidiary of that organization. If no parent organization code is entered, the newly created organization will be considered as a parent organization. End users do not need a parent organization code and have no organization information. The rest of the process is the same as registering as an organizational user.
*Organization Name	Customize the organization name.
*Registration method	Please select Email registration to register an account.
*Password	Set the account password.
*Confirm Password	Confirm the password again.

NOTICE

- The icon * indicates the item is mandatory.
- Registering end users do not need to fill in the parent organization code.

Step 4: Tick the box **I have read and agree to the Privacy Agreement**.

Step 5: Click **Register now** to complete the account registration.

11.3.3 Login

YiCloud APP supports password login and verification login.

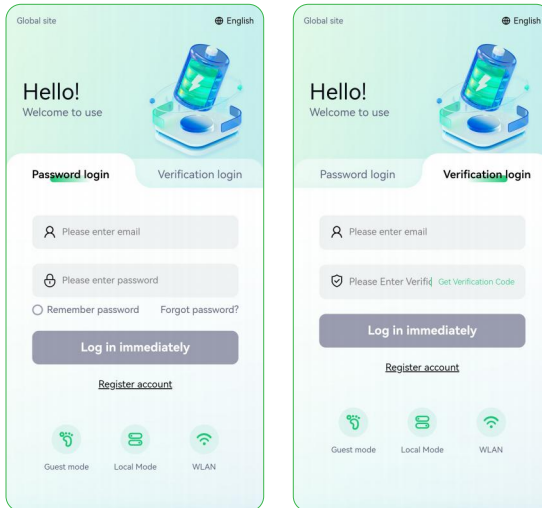

Figure 11-6 Password & Verification Login

Password Login

Step 1: Enter the Email on the login interface.

Step 2: Enter the password.

Step 3: Click **Log in immediately** to enter the overview page.

Verification Login

Step 1: Click **Verification Login** to enter the verification code login interface.

Step 2: Enter the email.

Step 3: Click **Get Verification Code**, and then enter the obtained verification code. The verification code is valid for 10 minutes, and you can request a new verification code after 60 seconds.

Step 4: Click **Log in immediately** to enter the overview page.

11.3.4 Create New Plant

NOTICE

- Different types of plants may result in slight differences in the **Create a New Plant** interface. Please refer to the actual interface.

Step 1: Click **Monitoring** on the homepage to enter the monitoring page.

Step 2: Click  to enter the **Create New Plant** page.



Figure 11-7 Creat New Power Station

Step 3: Fill in the information of the plant.

A screenshot of a mobile application interface titled "Create New Plant". The form contains several fields: "*Plant Type" with a dropdown menu; "*Plant name" with a text input field; "*Region" with a dropdown menu (Country, province, city, country); "*Address" with a text input field; "*Longitude" with a text input field (Please enter longitude E); and "*Latitude" with a text input field (Please enter latitude N). Below the form is a "Power Plant Image" section with a plus icon in a square box. At the bottom of the screen are two buttons: "Cancel" and "Create plant".

Figure 11-8 Information of Creating New Plant

Table 11-2 Parameters for Creating New Plant

Item	Explanation
*Plant Type	Select Residential for solar plant or Commercial for energy storage plant.
*Plant name	Enter the name of the plant.
*Region	Select the province, city, and district.
*Address	The location of the plant, which can be added in two ways: <ul style="list-style-type: none"> • Manual input: Manually enter the location in the input box. • Automatic acquisition: The system automatically acquires the address of the location of the plant.
*Longitude/Latitude	After obtaining the address, the longitude and latitude will be automatically filled. You can also fill in the longitude and latitude manually.
Power Plant Image	Click + to upload images.

i NOTICE

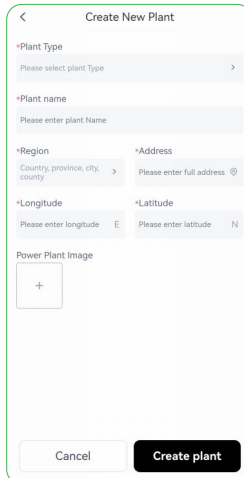
- The icon * indicates the item is mandatory.

Step 4: After completing the parameter settings, click **Create plant**.

Step 5: After the plant is created, click **Add a collector** to add a new device and click **Add authorization** to authorize users.

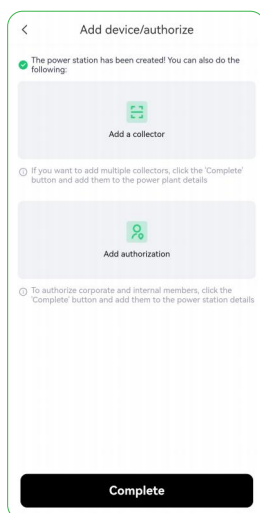

Figure 11-9 Successfully Creating

NOTICE

- Details of the plant can be viewed after five minutes of creation.
- Different plant types may result in different parameters displayed on the interface. Please refer to the actual interface.

11.3.5 Add a Device

Step 1: Click **Add a collector** after creating a new plant.

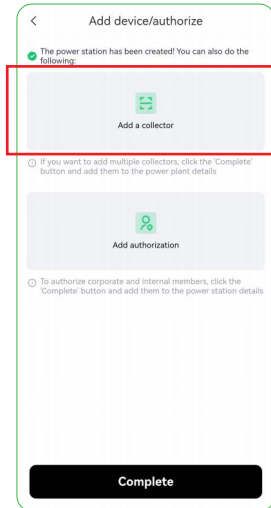

Figure 11-10 Add a Collector

Or click ... on the plant details page and then click **Add Device**.

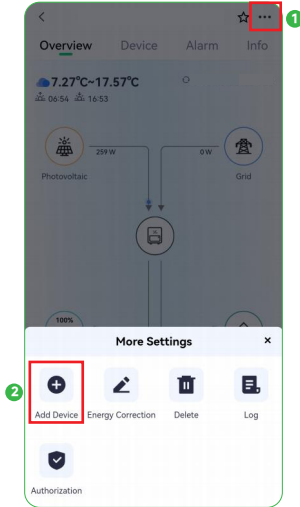

Figure 11-11 Add Device

Step 2: Click Add.

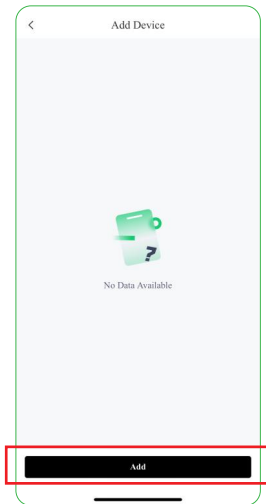



Figure 11-12 Click Add

Step 3: Enter the Series number.

- » Scan the QR code to add device

Click  to add device and click Confirm to accept the permission request. Scan the QR code on the communication device. After confirming that the software has recognized it correctly. Click **Confirm** to add the device.

Or click **Import from gallery** to import the QR code image. After confirming that the software has recognized the device correctly, click **Confirm** to add the communication device.

When the current environment is too dark to recognize the QR code, click **Tap to light up** to turn on the flashlight.

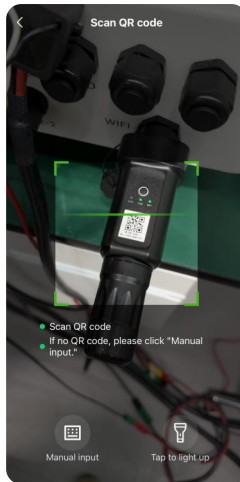

Figure 11-13 Scan QR Code

- » Manually input

Enter the serial number of the device directly. Only numbers or letters are allowed to be entered.

Step 4: Click **Save**. After the device is successfully added, wait for the device to report data, and then data from Overview, Maintenance, and Monitoring can be managed.

11.3.6 WLAN Configuration

Step 1: Click **WLAN Configuration** on the login interface or **Services** on the bottom after login.

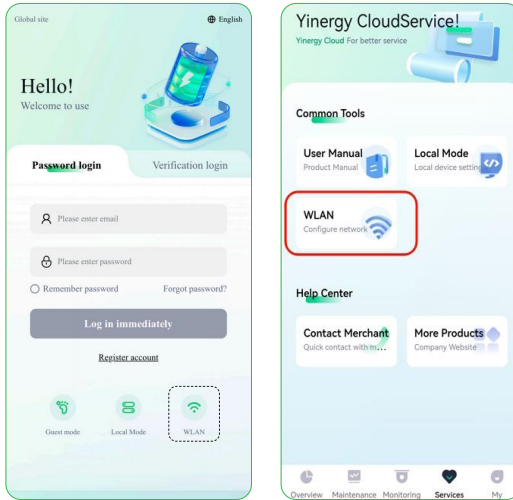

Figure 11-14 WLAN Configuration

Step 2: Enter the QR Code scanning page, allow camera access permission, scan the QR code of the device SN, or type the device SN. If the device has been added, skip this step.

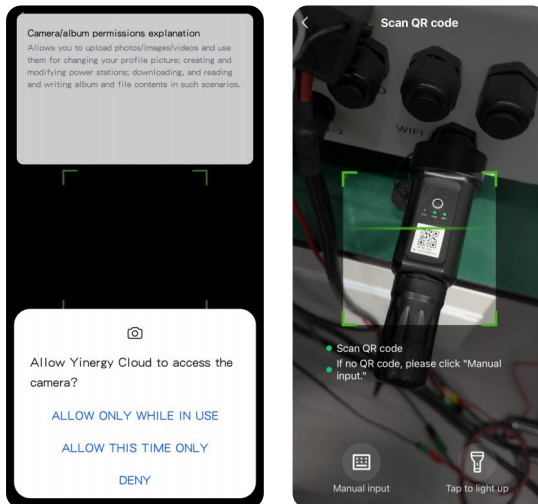

Figure 11-15 Scan QR Code of the Device SN

Step 3: Connect to the Wi-Fi at your home. By default, a password is required. If there is no password, turn off **Do you need a password** and click **Next step (2/3)**.

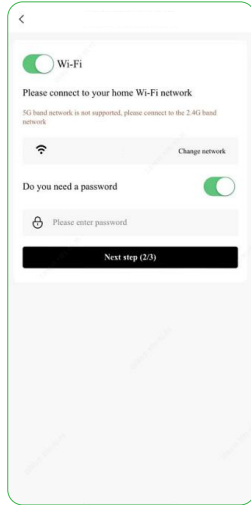

Figure 11-16 Connect to Home WiFi

Step 4: A prompt will appear to connect to the device network. The SSID of the device network is **Dongle-XXXXXXXX** (last eight digits of SN). As for password, please contact our after-sales service center.



Figure 11-17 Connect to Device Network

Step 5: After connecting to the device network, click **Start Configuration**.

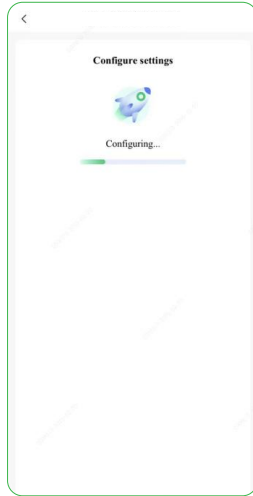

Figure 11-18 Configuring

Step 6: Configuration is completed successfully.

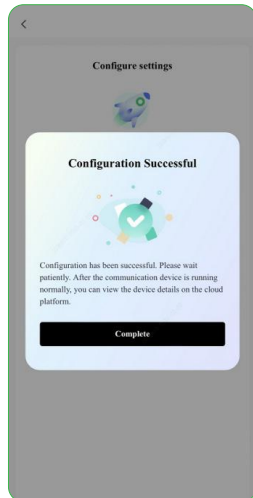

Figure 11-19 Configuration Completed

i NOTICE

- If it is necessary to switch to Ethernet configuration, turn off the Wi-Fi switch in the first step, and then it will be switched to Ethernet. Click **Next step** for configuration. When configuring Ethernet, it is also necessary to connect to the device network. The SSID and the password of the device is the same.

11.3.7 Setting Parameters via Yinergy Cloud

Inverter can be remote controlled by Yinergy Cloud.

Step 1: After login, find your own power plant on the **Monitoring** page.

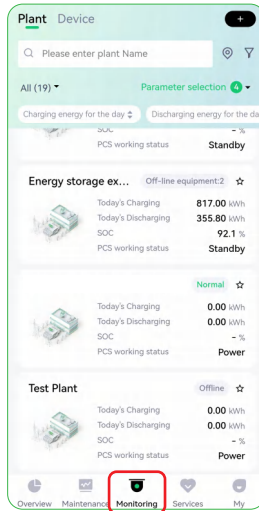

Figure 11-20 Plant list

Step 2: Select **Device**, choose **Distributed inverter** in the drop-down list and find your inverter.

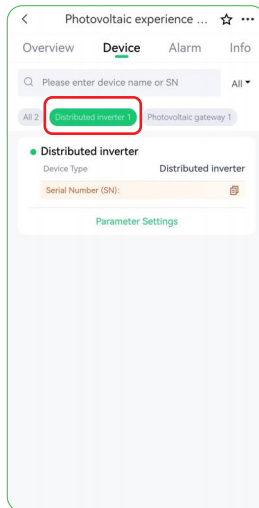

Figure 11-21 Distributed Inverter

Step 3: Select a certain Inverter and check the inverter firmware version.

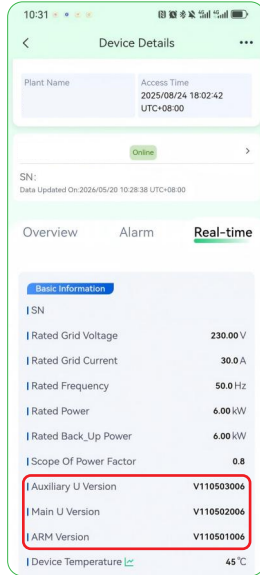

Figure 11-22 Inverter Firmware Version

Step 4: Click ... in the upper right corner. Click **Remote control**.

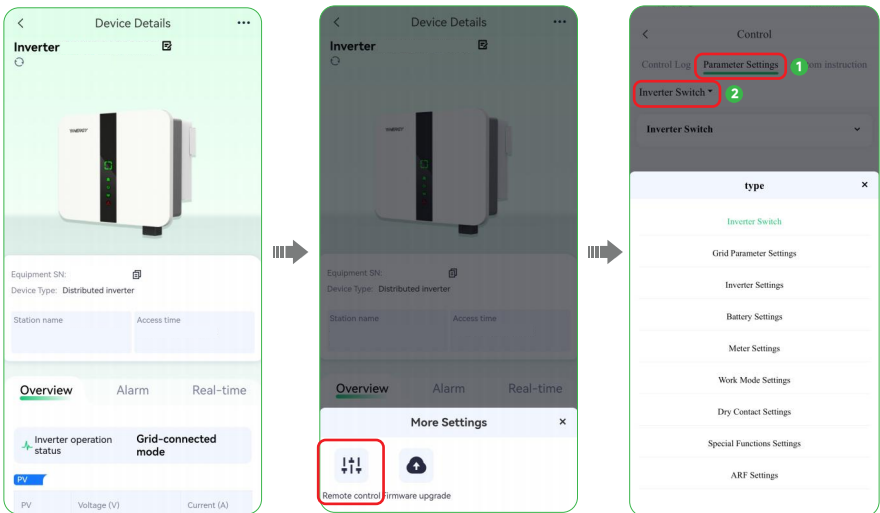

Figure 11-23 Select Remote Control

11.3.7.1 Inverter Switch

In this interface, user can start up or shut down the inverter.

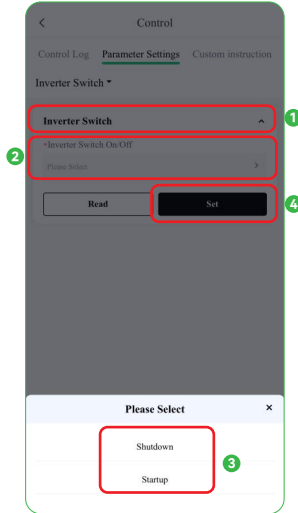

Figure 11-24 Inverter Switch

11.3.7.2 Grid Parameter Settings

Before changing the grid parameters, please unlock grid settings with default password. As for password, please contact our after-sales service center. Please change the password by clicking **Change Password**.

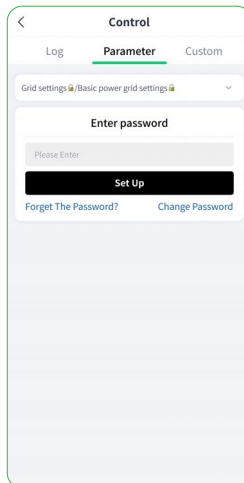

Figure 11-25 Grid parameter settings

Grid Code

Step 1: Select **Grid Parameter Settings**, click **Grid Code** and select the corresponding country's name or country code.

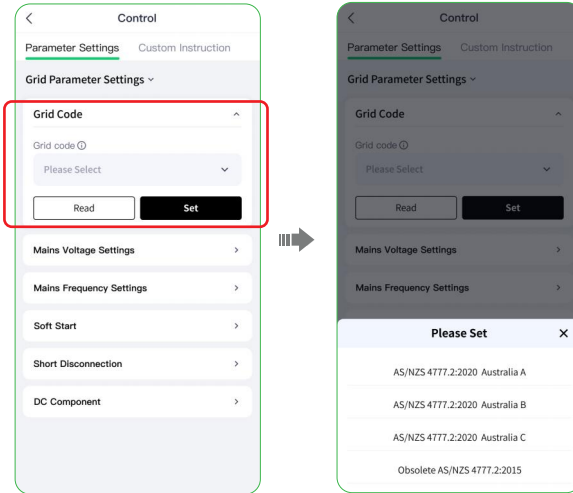

Figure 11-26 Set Grid Code

NOTICE

- The grid code should be chosen at this step. And the parameters also should be set if the grid company has the different requirements.

Step 2: Click **Set**.

Upper Connection and Reconnection Frequency

Click **Read** to automatically read parameters from the inverter or set parameters manually by user.

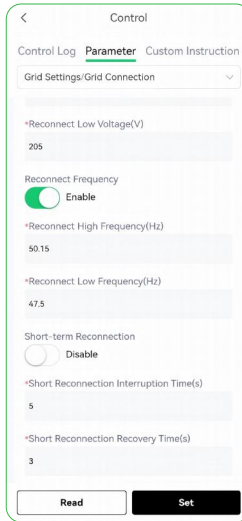

Figure 11-27 Set Upper Connection/Reconnection Frequency

Anti Backflow

Anti Backflow function can be realized by reading/setting export active power limit.

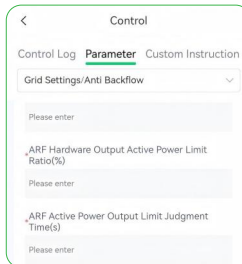

Figure 11-28 Set Anti-Backflow Function

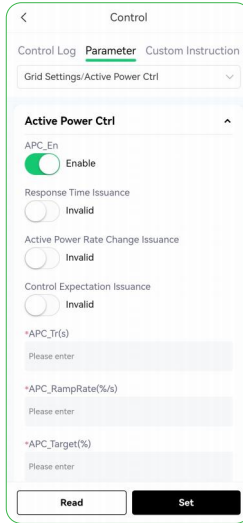

Figure 11-29 Set Active Power Control

11.3.7.3 Inverter Settings

In this interface, user can set **Time Settings**, **Active Power Control**, **Power Factor Settings**, **Reactive Power Control**, **Voltage Power Control**, **Frequency Power Control** and **First Reconnection**.

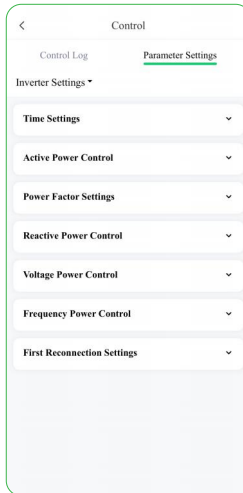

Figure 11-30 Inverter Settings

Time Settings

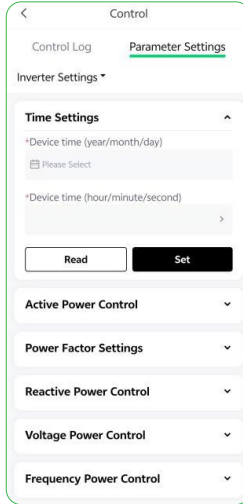

Figure 11-31 Time Settings

Table 11-3 Device Time Settings

Item	Description
Device time (year/month/day)	Set the year/month/day of the device time
Device time (hour/minute/second)	Set the hour/minute/second of the device time

Q(P) Mode

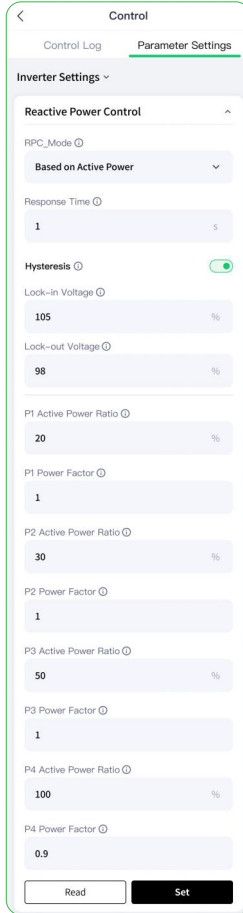

Figure 11-32 Q(P) Mode Settings

Table 11-4 Q(P) Mode Settings

No.	Item	Explanation
1	Reactive Power Control Based on Active Power	Enable/Disable Q(P) mode: Adjust Reactive Power Based on Active Power
2	Response Time	Inverter will respond to the reactive power period with first-order low-pass curve based on Response Time

No.	Item	Explanation
3	Hysteresis	Enable/Disable Hysteresis: <ul style="list-style-type: none"> • If voltage is higher than Lock-in Voltage, start reactive power control. • If voltage lower than Lock-out Voltage, stop reactive power control.
4	Lock-in Voltage	Threshold for starting reactive power hysteresis
5	Lock-out Voltage	Threshold for stopping reactive power hysteresis
6	P1 Active Power Ratio	Active power ratio of P1 on Q(P) curve
7	P1 Power Factor	Power factor of P1 on Q(P) curve
8	P2 Active Power Ratio	Active power ratio of P2 on Q(P) curve
9	P2 Power Factor	Power factor of P2 on Q(P) curve
10	P3 Active Power Ratio	Active power ratio of P3 on Q(P) curve
11	P3 Power Factor	Power factor of P3 on Q(P) curve
12	P4 Active Power Ratio	Active power ratio of P4 on Q(P) curve
13	P4 Power Factor	Power factor of P4 on Q(P) curve

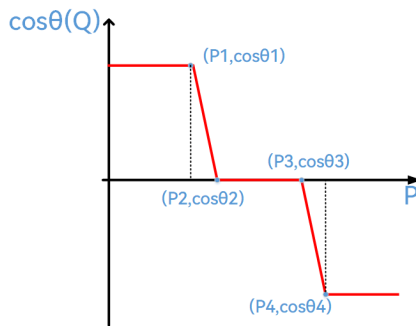

Figure 11-33 Q(P) Curve

Q(U) Mode

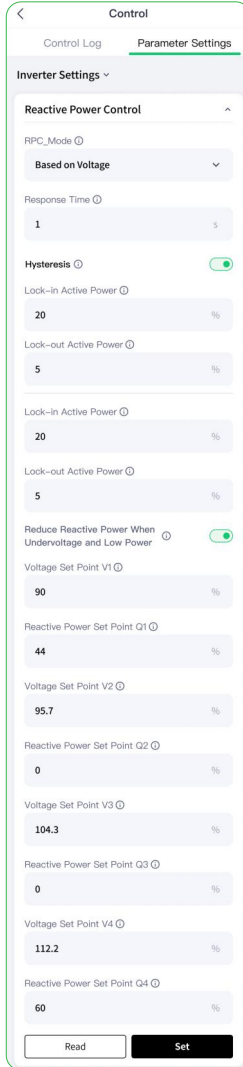

Figure 11-34 Q(U) Mode Settings

Table 11-5 Q(U) Mode Settings

No.	Item	Explanation
1	Reactive Power Control Based on Voltage	Q(U) mode: Adjust reactive power based on voltage
2	Response Time	Inverter will respond to the reactive power period with first-order low-pass curve based on Response Time
3	Hysteresis	Enable/Disable Hysteresis : <ul style="list-style-type: none"> • If voltage is higher than Lock-in Voltage, start reactive power control. • If voltage lower than Lock-out Voltage, stop reactive power control.
4	Lock-in Active Power	Threshold for starting reactive power hysteresis
5	Lock-out Active Power	Threshold for stopping reactive power hysteresis
6	Reduce Reactive Power When Undervoltage and Low Power	Enable/Disable to reduce reactive power when the inverter is undervoltage and at low power
7	Voltage Set Point V1	Voltage set point V1 on Q(U) curve
8	Reactive Power Set Point Q1	Reactive power set point Q1 on Q(U) curve
9	Voltage Set Point V2	Voltage set point V2 on Q(U) curve
10	Reactive Power Set Point Q2	Reactive power set point Q2 on Q(U) curve
11	Voltage Set Point V3	Voltage set point V3 on Q(U) curve
12	Reactive Power Set Point Q3	Reactive power set point Q3 on Q(U) curve
13	Voltage Set Point V4	Voltage set point V4 on Q(U) curve
14	Reactive Power Set Point Q4	Reactive power set point Q4 on Q(U) curve

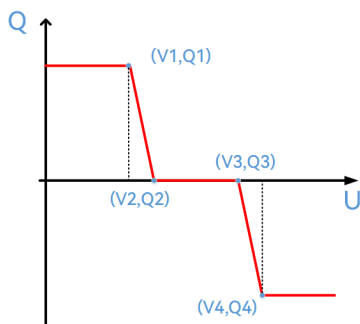

Figure 11-35 Q(U) Curve

P(U) Mode

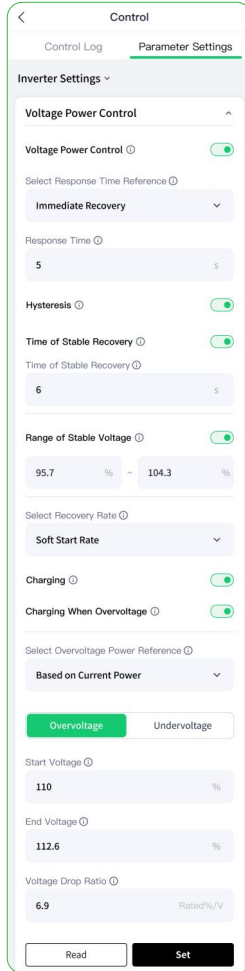

Figure 11-36 P(U) Mode Settings

Table 11-6 P(U) Mode Settings

No.	Item	Explanation
1	Voltage Power Control	Enable/Disable P(U) mode: Voltage Power Control
2	Select Response Time Reference	Recovery method after overvoltage/undervoltage recovery
3	Response Time	Inverter will control power changes with first-order low-pass curve after Response Time

No.	Item	Explanation
4	Hysteresis	Take the power when overvoltage/undervoltage as the maximum power before the voltage recovery
5	Time of Stable Recovery_ Enable	Enable/Disable set value or default value of time
6	Time of Stable Recovery	Period not to control power after voltage is in the stable range
7	Range of Stable Voltage	Enable/Disable set value or default value of voltage
8	Min. ~ Max. Stable Voltage	<ul style="list-style-type: none"> • When normal, start limiting power if frequency exceeds the range, otherwise no limitation. • When abnormal, it will no longer limit the power rise if frequency returns to the range, otherwise the power is not allowed to exceed Min. Stable Voltage
9	Select Recovery Rate	Select recovery at Soft Start Rate or Normal Rate
10	Charging	Enable/Disable battery charging
11	Charging When Overvoltage	Enable/Disable battery charging when overfrequency
12	Select Overvoltage Power Reference	Select to shed load based on Current Power or Rated Power
13	Start Voltage	Threshold for starting to limit power
14	End Voltage	Threshold for ending to limit power
15	Voltage Drop Ratio	Power drop ratio in the set voltage control interval

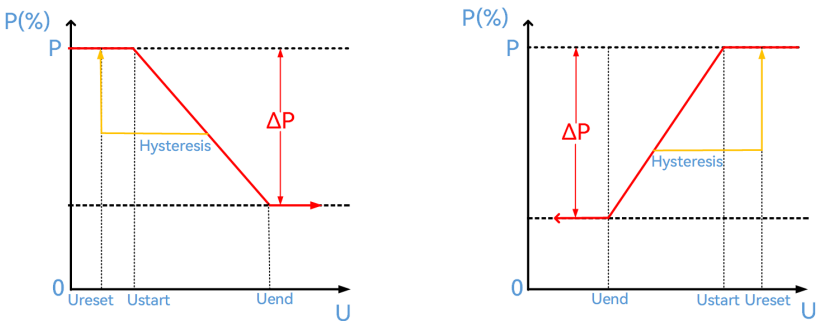

Figure 11-37 P(U) Curve

P(F) Mode

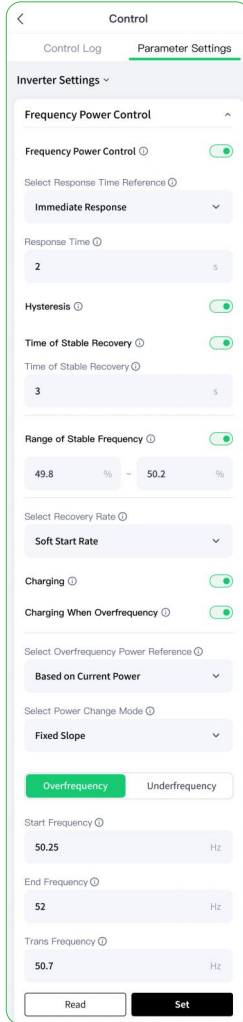

Figure 11-38 P(F) Mode Settings

Table 11-7 P(F) Mode Settings

No.	Item	Explanation
1	Frequency Power Control	Enable/Disable P(F) mode: Frequency Power Control
2	Select Response Time Reference	Select response method after overfrequency/underfrequency recovery
3	Response Time	Inverter will start recovery after Response Time
4	Hysteresis	Take the power when overfrequency/underfrequency as the maximum power before the frequency recovery
5	Time of Stable Recovery	Enable/Disable set value or default value
6	Time of Stable Recovery	Period not to control power after frequency is in the stable range
7	Range of Stable Frequency	Enable/Disable set value or default value of frequency
8	Min. ~ Max. Stable Frequency	<ul style="list-style-type: none"> When normal, start limiting power if frequency exceeds the range, otherwise no limitation. When abnormal, it will no longer limit the power rise if frequency returns to the range, otherwise the power is not allowed to exceed Min. Stable Frequency
9	Select Recovery Rate	Select recovery at Soft Start Rate or Normal Rate
10	Charging	Enable/Disable battery charging
11	Charging When Overfrequency	Enable/Disable battery charging when overfrequency
12	Select Overfrequency Power Reference	Select to shed load based on Current Power or Rated Power
13	Select Power Change Mode	Select to draw a power curve based on Fixed Slope or Fixed Frequency
14	Start Frequency	Threshold for starting to limit power
15	End Frequency	Threshold for ending to limit power
16	Trans Frequency	Power zero point of the power change curve

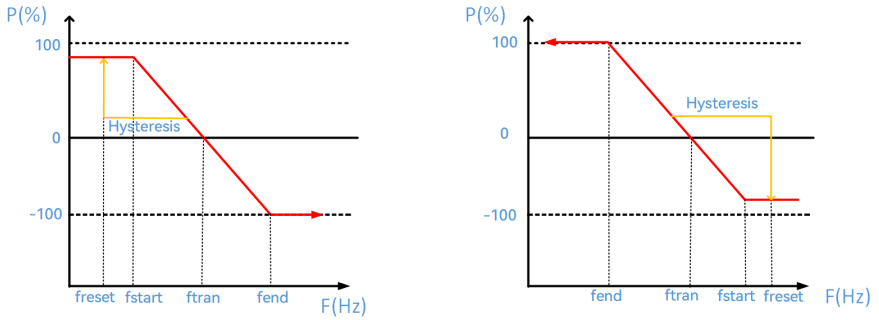

Figure 11-39 P(F) Curve

11.3.7.4 Battery Settings

In this interface, user can set **Battery 1 model**, **Battery 1 type**, **Battery 1 Boost Switch**, **Battery 1 Force Charge Wait Time (min)** and **Battery 1 Force Charge Confirm**.

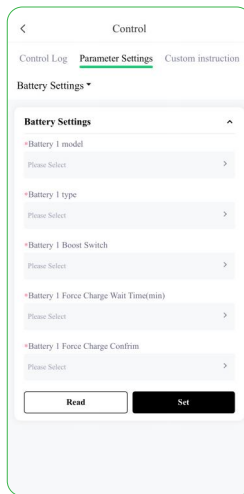

Figure 11-40 Battery Settings

Take **Battery 1** type as an example:

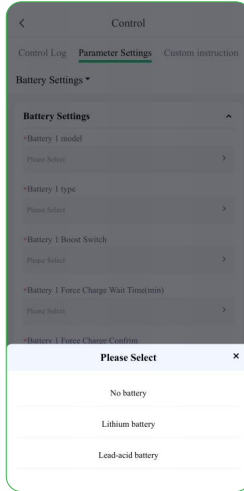

Figure 11-41 Select Battery Type

11.3.7.5 Meter Settings

In this interface, user can set **Meter Settings**, including **Electric meter model** and **Dual CT Enabled Electric Meter**.

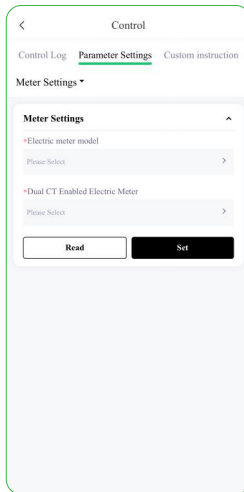

Figure 11-42 Meter Settings

11.3.7.6 Work Mode Settings

In this interface, user can set **Work mode selection** and **Work Mode Settings**.

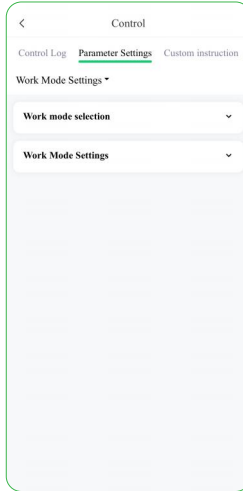

Figure 11-43 EMS

Take **Work mode selection** as an example:

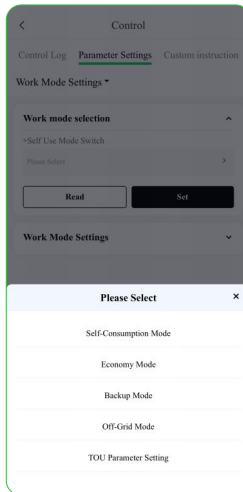

Figure 11-44 Select Work Mode

NOTICE

- For detailed information for Work Mode, please refer to [9.9.2 System Work Mode](#).

11.3.7.7 Dry Contact Settings

In this interface, user can set **Dry Contact 1** and **Dry Contact 2**.

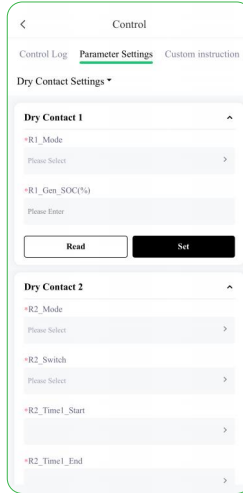

Figure 11-45 Dry Contact Settings

11.3.7.8 Special Functions Settings

In this interface, user can set **Leakage Current Protection**, **Insulation Impedance**, **Settings**, **Generator Settings** and **Safety Special**.

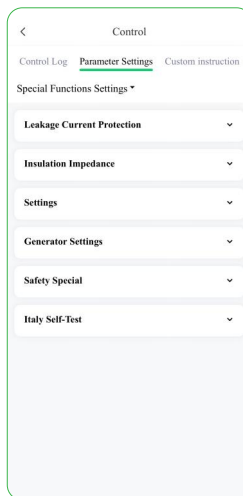

Figure 11-46 Special Functions Settings

11.3.7.9 ARF Settings

In this interface, user can set **ARF Settings**.

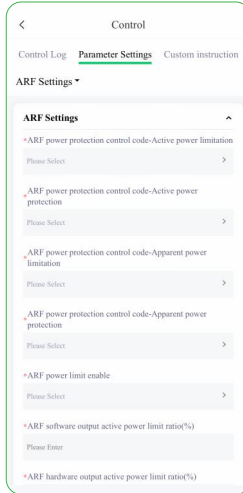

Figure 11-47 ARF Settings

11.3.8 Plant Interface

On the plant list, click the plant name to enter the overview page by default, and you can view the plant's data and the device information.

Energy Storage Plant Interface

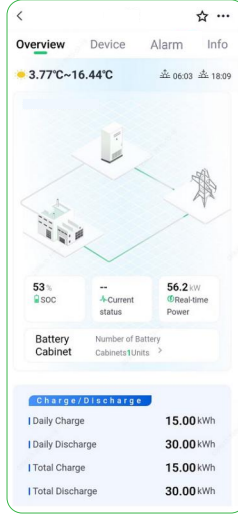

Figure 11-48 Energy Storage Plant Interface

Photovoltaic Plant Interface



Figure 11-49 Photovoltaic Plant Interface

 **NOTICE**

- When a power station is created, details can be viewed after five minutes.
- Different power station types may result in different parameters displayed on the interface. Please refer to the actual interface.

12.1 Disconnecting the Inverter from Voltage Sources

Prior to performing any work on the product, always disconnect it from all voltage sources as described in this section. Always adhere to the prescribed sequence.



WARNING!

- Danger to life due to electric shock from destruction of the measuring device due to overvoltage!
- Please pay attention to all loads.
- Overvoltage can damage a measuring device and result in voltage being present in the enclosure of the measuring device. Touching the live enclosure of the measuring device results in death or lethal injuries due to electric shock.
- Only use measuring devices with a DC input voltage range of 1100 V or higher.

Step 1: Disconnect the miniature circuit breaker and secure against reconnection.

Step 2: Disconnect the DC switch and secure against reconnection.

Step 3: Wait until the LEDs have gone out.

Step 4: Use a current clamp meter to ensure that no current is present in the DC cables.



DANGER!

- Please pay attention to all loads. Danger to life due to electric shock when touching exposed DC conductors or DC plug contacts if the DC connectors are damaged or loose!
- The DC connectors can break or become damaged, become free of the DC cables, or no longer be connected correctly if the DC connectors are released and disconnected incorrectly. This can result in the DC conductors or DC plug contacts being exposed. Touching live DC conductors or DC plug connectors will result in death or serious injury due to electric shock.
- Wear insulated gloves and use insulated tools when working on the DC connectors.
- Ensure that the DC connectors are in perfect condition and that none of the DC conductors or DC plug contacts are exposed.
- Carefully release and remove the DC connectors as described in the following.

Step 5: Release and remove DC plug connectors, insert a wrench tool into the slots and press the wrench tool with an appropriate force.

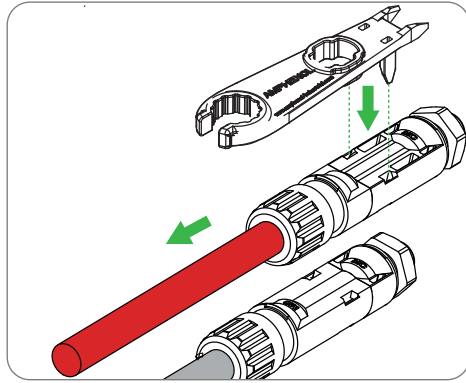

Figure 12-1 Remove DC Connectors

Step 6: Ensure that no voltage is present between the positive terminal and negative terminal at the DC inputs using a suitable measuring device.

Step 7: Disconnect the AC connector: Loosen the screw on the latch with a screwdriver.

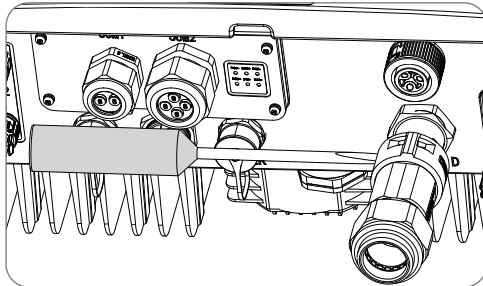

Figure 12-2 Loosening the Screw

Step 8: Slightly pull the connector out.

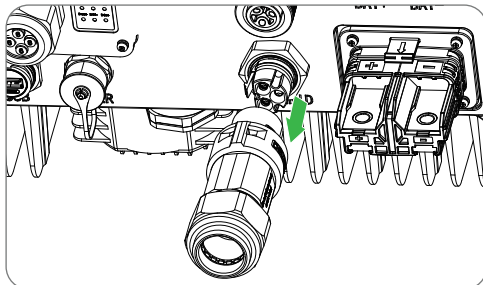

Figure 12-3 Pulling the Connector Out

Step 9: Insert a screwdriver and rotate the latch. Remove the female end of the cable to unlock the BACKUP load connector.

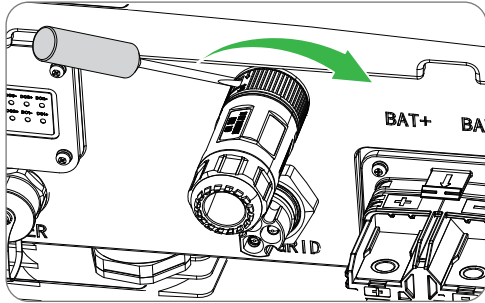

Figure 12-4 Rotating the Latch

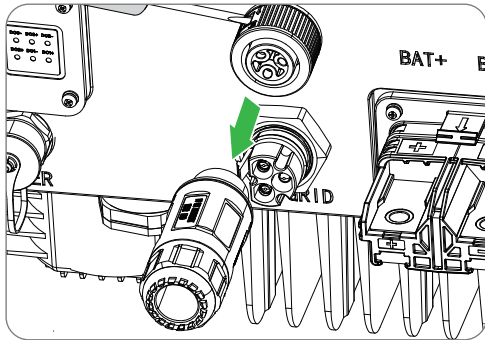

Figure 12-5 Remove Backup Connector

Step 10: Disconnect the battery connectors: Insert a flat screwdriver into the notch of connectors and slightly pull out the connector.

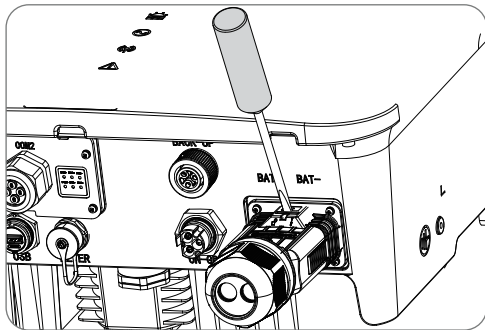

Figure 12-6 Inserting a Screwdriver

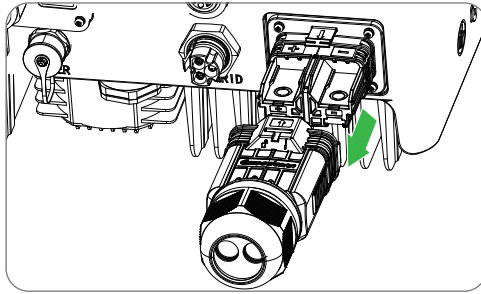

Figure 12-7 Pulling Out the Connector

Step 11: Remove the communication cover. Remove the communication cable in reverse order by referring to [8.6 Communication Connection](#).

Step 12: Hold down the buckle on the side of the Dongle and pull out the Dongle terminal.

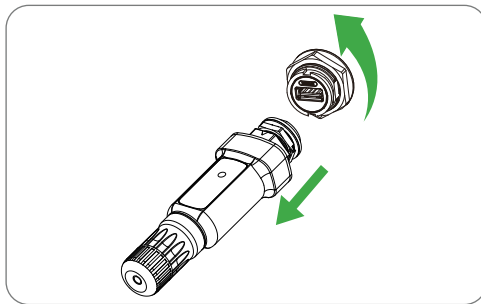

Figure 12-8 Pull Out the Dongle

12.2 Dismantling the Inverter

After disconnecting all electrical connections as described in [12.1 Disconnecting the Inverter from Voltage Sources](#), the inverter can be removed as follows.

Step 1: Dismantle the inverter referring to [7.2 Installation Procedures](#) in reverse steps.

Step 2: If necessary, remove the wall-mounting bracket from the wall.

Step 3: If the inverter will be reinstalled in the future, please refer to [4 Transportation and Storage](#) for a proper conservation.

13.1 Power off



DANGER!

- While operating and maintaining the inverter, please turn it off for processing. Operating the equipment with power may cause damage to the inverter or cause a risk of electric shock.
- After the inverter is powered off, it will take a certain amount of time for internal components to discharge. Please wait until the equipment is fully discharged according to the required label time requirements. Do not connect one PV array to multiple inverter, it may cause damage of inverter.

Step 1: Send a shutdown command on the App.

Step 2: Turn off the AC circuit breaker on the ON-GRID side of the inverter.

Step 3: Turn off the AC circuit breaker on the BACK-UP side of the inverter.

Step 4: Turn off the energy storage circuit breaker between the inverter and the battery.

Step 5: Turn off the DC switch of the inverter.

13.2 Troubleshooting

Please follow the methods below for troubleshooting. If the troubleshooting method cannot solve the issue, please contact the after-sales service center.

When contacting the after-sales service center, please collect the following information for quick resolution of the problem.

- Inverter information, such as serial number, software version, equipment installation time, fault occurrence time, fault occurrence frequency, etc.
- The installation environment of the equipment, such as weather conditions, presence of obstructed or shadows on the components, etc. It is recommended to provide photos, videos, and other files as auxiliaries to assist in analyzing problems.

No.	Fault Name	Diagnosis and Solutions
1	Grid off	<p>Fault Reason:</p> <ul style="list-style-type: none"> • Power grid outage. • The AC line or AC switch is disconnected. <hr/> <p>Solutions:</p> <ul style="list-style-type: none"> • The alarm will automatically disappear after the power supply of the power grid is restored. • Check if the AC circuit or AC switch is disconnected.
2	Grid over voltage protect	<p>Fault Reason:</p> <p>The grid voltage is higher than the allowable range, or the duration of high voltage exceeds the set value for high voltage crossing</p> <hr/> <p>Solutions:</p> <ul style="list-style-type: none"> • If it occurs accidentally, it may be due to a short-term abnormality in the power grid. After detecting that the power grid is normal, the inverter will resume normal operation without manual intervention. • If it occurs frequently, please check if the grid voltage is within the allowable range. <ul style="list-style-type: none"> » If the grid voltage exceeds the allowable range, please contact the local power operator. » If the grid voltage is within the allowable range, it is necessary to modify the inverter grid over voltage protection point, HVRT, or turn off the grid over voltage protection function with the consent of the local power operator. • If it cannot be restored for a long time, please check whether the AC side circuit breaker and output cable are connected properly.
3	Grid under voltage protect	<p>Fault Reason:</p> <p>The grid voltage is below the allowable range, or the duration of low voltage exceeds the set value of low voltage crossing.</p> <hr/> <p>Solutions:</p> <p>The cable bundling complies with the wiring requirements, is properly distributed, and free from damage.</p>

No.	Fault Name	Diagnosis and Solutions
4	Grid over frequency protect	<p>Fault Reason:</p> <p>The power grid is abnormal, and the actual frequency of the power grid is higher than the local power grid standard requirements.</p> <hr/> <p>Solutions:</p> <ul style="list-style-type: none"> • If it occurs accidentally, it may be due to a short-term abnormality in the power grid. After detecting that the power grid is normal, the inverter will resume normal operation without manual intervention. • If it occurs frequently, please check if the grid frequency is within the allowable range. <ul style="list-style-type: none"> » If the grid frequency exceeds the allowable range, please contact the local power operator. » If the grid frequency is within the allowable range, it is necessary to modify the inverter grid over frequency protection point or turn off the grid over frequency protection function with the consent of the local power operator.
5	Grid under frequency protect	<p>Fault Reason:</p> <p>The power grid is abnormal, and the actual frequency of the power grid is lower than the local power grid standard requirements.</p> <hr/> <p>Solutions:</p> <ul style="list-style-type: none"> • If it occurs accidentally, it may be due to a short-term abnormality in the power grid. After detecting that the power grid is normal, the inverter will resume normal operation without manual intervention. • If it occurs frequently, please check if the grid frequency is within the allowable range. <ul style="list-style-type: none"> » If the grid frequency exceeds the allowable range, please contact the local power operator. » If the grid frequency is within the allowable range, it is necessary to modify the inverter grid under frequency protection point or turn off the grid under frequency protection function with the consent of the local power operator.

No.	Fault Name	Diagnosis and Solutions
6	Grid frequency shift protection	<p>Fault Reason:</p> <p>The power grid is abnormal, and the actual frequency change rate of the power grid does not comply with local power grid standards.</p> <hr/> <p>Solutions:</p> <ul style="list-style-type: none"> • If it occurs accidentally, it may be due to a short-term abnormality in the power grid. After detecting that the power grid is normal, the inverter will resume normal operation without manual intervention. • If it occurs frequently, please check if the power grid frequency is within the allowable range. <ul style="list-style-type: none"> » If the grid frequency exceeds the allowable range, please contact the local power operator. » If the power grid frequency is within the allowable range, please contact your dealer or after-sales service center.
7	Anti-island protection	<p>Fault Reason:</p> <p>The power grid has been disconnected, and due to the presence of loads, the grid voltage has been maintained. According to safety regulations and protection requirements, the grid connection has been stopped.</p> <hr/> <p>Solutions:</p> <ul style="list-style-type: none"> • Confirm if the power grid is disconnection. • Contact your dealer or after-sales service center.
8	Low voltage ride through (LVRT) fault	<p>Fault Reason:</p> <p>The power grid is abnormal, and the time for abnormal power grid voltage exceeds the time specified by LVRT.</p> <hr/> <p>Solutions:</p> <ul style="list-style-type: none"> • If it occurs accidentally, it may be due to a short-term abnormality in the power grid. After detecting that the power grid is normal, the inverter will resume normal operation without manual intervention. • If it occurs frequently, please check whether the power grid frequency is within the allowable range. If not, please contact the local power operator; If so, please contact your dealer or after-sales service center.

No.	Fault Name	Diagnosis and Solutions
9	High voltage ride through (HVRT) fault	<p>Fault Reason:</p> <p>The power grid is abnormal, and the time for abnormal power grid voltage exceeds the time specified by HVRT.</p> <hr/> <p>Solutions:</p> <ul style="list-style-type: none"> • Please refer to the No.8.
10	Ground fault circuit interrupter (GFCI) Protection	<p>Fault Reason:</p> <p>The input insulation impedance to ground decreases during the operation of the inverter.</p> <hr/> <p>Solutions:</p> <ul style="list-style-type: none"> • If it occurs accidentally, it may be caused by an accidental abnormality in the external circuit. After the fault is cleared, normal operation will resume without manual intervention. • If it occurs frequently or cannot be restored for a long time, please check if the insulation impedance of the photovoltaic string to the ground is too low.
11	Direct current injection (DCI) Protection	<p>Fault Reason:</p> <p>The DC component of the inverter output current is higher than the safety regulations or the machine's default allowable range.</p> <hr/> <p>Solutions:</p> <ul style="list-style-type: none"> • If the abnormality is caused by an external fault (such as power grid abnormality, frequency abnormality, etc.), the inverter will automatically resume normal operation after the fault disappears, without manual intervention. • If the alarm occurs frequently and affects the normal power generation of the power plant, please contact your dealer or after-sales service center.

No.	Fault Name	Diagnosis and Solutions
12	Low insulation impedance	<p>Fault Reason:</p> <ul style="list-style-type: none"> • The photovoltaic string is short circuited to the protective ground. • The installation environment of the photovoltaic string is relatively humid for a long time and the insulation of the line to the ground is poor. <hr/> <p>Solutions:</p> <ul style="list-style-type: none"> • Check the impedance of the photovoltaic string to the protective ground. If the resistance value is greater than 50 kΩ, it is normal. If the resistance value is less than 50 kΩ, please investigate the short circuit point and rectify it. • Check if the protective ground wire of the inverter is correctly connected. • If it is confirmed that the impedance is indeed lower than the default value in a rainy and cloudy environment, please reset the "insulation impedance protection point" via APP.
13	Abnormal system grounding	<p>Fault Reason:</p> <ul style="list-style-type: none"> • The protective ground wire of the inverter is not connected. • When the output of the photovoltaic string is grounded, the AC output cables L and N of the inverter are reversed. <hr/> <p>Solutions:</p> <ul style="list-style-type: none"> • Please confirm if the protective ground wire of the inverter is not connected properly. • If the output of the photovoltaic string is grounded, please confirm whether the AC output cables L and N of the inverter are reversed.

No.	Fault Name	Diagnosis and Solutions
14	Internal communication disconnection	<p>Fault Reason:</p> <p>Frame format error</p> <ul style="list-style-type: none"> • Parity error • Can bus offline • Hardware CRC verification error • When sending (receiving), the control bit is set to receive (send) • Transfer to units that are not allowed <hr/> <p>Solutions:</p> <p>Disconnect the AC output side switch and DC input side switch, after 5 minutes, connect the AC output side switch and DC input side switch. If the fault persists, please contact your dealer or after-sales service center.</p>
15	Abnormal AC sensor	<p>Fault Reason:</p> <p>Abnormal sampling of AC sensor.</p> <hr/> <p>Solutions:</p> <p>Disconnect the AC output side switch and DC input side switch, after 5 minutes, connect the AC output side switch and DC input side switch. If the fault persists, please contact your dealer or after-sales service center.</p>
16	Abnormal Leakage current sensor	<p>Fault Reason:</p> <p>Abnormal sampling of leakage current sensor</p> <hr/> <p>Solutions:</p> <p>Disconnect the AC output side switch and DC input side switch, after 5 minutes, connect the AC output side switch and DC input side switch. If the fault persists, please contact your dealer or after-sales service center.</p>
17	Abnormal relay	<p>Fault Reason:</p> <ul style="list-style-type: none"> • Abnormal relay (relay short circuit) • Abnormal control circuit • Abnormal AC measurement wiring (i.e. virtual connection or short circuit phenomenon) <hr/> <p>Solutions:</p> <p>Disconnect the AC output side switch and DC input side switch, after 5 minutes, connect the AC output side switch and DC input side switch. If the fault persists, please contact your dealer or after-sales service center.</p>

No.	Fault Name	Diagnosis and Solutions
18	Chamber over temperature	Fault Reason: <ul style="list-style-type: none"> • The installation position of the inverter is not ventilated • The ambient temperature is too high and exceeds 60 °C • Abnormal operation of internal fan
		Solutions: <ul style="list-style-type: none"> • Check whether the ventilation at the installation location of the inverter is good and whether the ambient temperature exceeds the maximum allowable ambient temperature range. • If there is no ventilation or the ambient temperature is too high, please improve its ventilation and heat dissipation conditions. • If the ventilation and ambient temperature are normal, please contact your dealer or after-sales service center.
19	Bus over voltage	Fault Reason: <ul style="list-style-type: none"> • PV voltage is too high • Abnormal inverter BUS voltage sampling
		Solutions: Disconnect the AC output side switch and DC input side switch, and after 5 minutes, close the AC output side switch and DC input side switch. If the fault persists, please contact your dealer or after-sales service center.
20	PV input over voltage	Fault Reason: The photovoltaic array configuration is incorrect, too many photovoltaic panels in series.
		Solutions: Check the series configuration of the corresponding photovoltaic array string to ensure that the open circuit voltage of the string is not higher than the maximum working voltage of the inverter.
21	PV continuous hardware over current	Fault Reason: <ul style="list-style-type: none"> • Incorrect photovoltaic array configuration. • Hardware damage
		Solutions: Disconnect the AC output side switch and DC input side switch, after 5 minutes, connect the AC output side switch and DC input side switch. If the fault persists, please contact your dealer or after-sales service center.

No.	Fault Name	Diagnosis and Solutions
22	PV continuous software over current	<p>Fault Reason:</p> <ul style="list-style-type: none"> • Incorrect photovoltaic array configuration • Hardware damage <hr/> <p>Solutions:</p> <p>Disconnect the AC output side switch and DC input side switch, after 5 minutes, connect the AC output side switch and DC input side switch. If the fault persists, please contact your dealer or after-sales service center.</p>

13.3 Maintenance

Regular maintenance is required for the inverter. The table below lists the operational maintenance for expressing the optimum device performance. More frequent maintenance service is needed in the worse work environment. Please make records of the maintenance.



WARNING!

- Only qualified person can perform the maintenance for the inverter.
- Only use the spare parts and accessories approved by Yinergy for maintenance.

13.3.1 Removing the Inverter



WARNING!

- Ensure that the inverter is powered off before operation.
- When operating the inverter, please wear personal protective equipment.

Step 1: Disconnect all electrical connections of the inverter, including DC line, AC line, communication line, communication module, and protective ground wire.

Step 2: Remove the inverter from the mounting bracket.

Step 3: Remove the mounting bracket.

Step 4: Properly store the inverter. If the inverter will be used in the future, ensure that the storage conditions meet the specified requirements.

13.3.2 Scrap Inverter

When the inverter cannot continue be used and needs to be scrapped, please dispose of the inverter according to the electrical waste disposal requirements of the country/region where the inverter is located.

The inverter cannot be treated as household waste.

13.3.3 Maintenance Routines

Maintaining Item	Maintaining Method	Maintaining Period
System Clean	Check the heat sink, air intake, and air outlet for foreign matter or dust.	Once 6-12 months
Electrical Connection	Check whether the cables are securely connected. Check whether the cables are broken or whether there is any exposed copper core.	Once 6-12 months
Sealing	Check whether all the terminals and ports are properly sealed. Reseal the cable hole if it is not sealed or too big.	Once a year
General status of inverter	Check if there is any damage on the inverter. Check if there is any abnormal sound when the inverter is running.	Once 6 months

13.4 Recycling and Disposal

Dispose of the packaging and replaced parts according to the rules applicable in the country where the device is installed.

NOTICE

- Do not dispose of the product together with the household waste but in accordance with the disposal regulations for electronic waste applicable at the installation site.

13.5 Service and Warranty

If you have any technical problems concerning our products, please contact Yinergy service. We require the following information in order to provide you with the necessary assistance:

- Inverter device type
- Inverter serial number
- Type and number of connected PV modules
- Error code
- Mounting location
- Installation date
- Warranty card

For more information, refer to the Warranty for your region at www.yinergy-solar.com.

When the customer needs warranty service during the warranty period, the customer must provide a copy of the invoice, factory warranty card, and ensure the electrical label of the inverter is legible. If these conditions are not met, Yinergy has the right to refuse to provide with the relevant warranty service.

• PV Input

	HI-1P3K-L-Y1	HI-1P3.68K-L-Y1	HI-1P4K-L-Y1	HI-1P4.6K-L-Y1	HI-1P5K-L-Y1	HI-1P6K-L-Y1
Max. Input Power [W]	4500	5500	6000	7000	7500	9000
Max. Input Voltage [V]				550		
Rated Input Voltage [V]				360		
Start-up Input Voltage [V]				90		
MPPT Operating Voltage Range [V]				90 ~ 520		
Max. Input Current [A]	20			20/20		
Max. Short Circuit Current [A]	27			27/27		
Max. Backfeed Current to Array [A]				0		
No. of MPP Trackers	1			2		
No. of String Per MPP Tracker				1		

• AC Output (On Grid)

	HI-1P3K-L-Y1	HI-1P3.68K-L-Y1	HI-1P4K-L-Y1	HI-1P4.6K-L-Y1	HI-1P5K-L-Y1	HI-1P6K-L-Y1
Rated Output Power [W]	3000	3680	4000	4600	5000	6000
Rated Output Apparent Power [VA]	3000	3680	4000	4600	5000	6000
Max. Output Apparent Power [VA]	3300	4048	4400	5060	5500	6600
Rated Grid Voltage [V]	L / N / PE, 230					
Rated Grid Frequency [Hz]	50					
Rated Output Current [A]	13	16	17.4	20	21.7	26.1
Max. Output Current [A]	14.3	17.6	19.1	22	24	28.7
Power Factor	~1 (Adjustable from 0.8 leading to 0.8 lagging)					
Total Harmonic Distortion, THDi	< 3%					
Max. Output Fault Current [A]	90 @ 3 μs					
Max. Output Overcurrent Protection [A]	81					

• AC Input (On Grid)

	HI-1P3K-L-Y1	HI-1P3.68K-L-Y1	HI-1P4K-L-Y1	HI-1P4.6K-L-Y1	HI-1P5K-L-Y1	HI-1P6K-L-Y1
Max. Input Apparent Power [VA]	6000	7300	8000	9200	10000	10000
Rated Grid Voltage [V]	L / N / PE, 230					
Rated Grid Frequency [Hz]	50					
Current (Inrush) [A]	90 @ 3 μs					
Max. Input Current [A]	26.1	32	34.8	40	43.5	43.5

• Battery

	HI-1P3K-L-Y1	HI-1P3.68K-L-Y1	HI-1P4K-L-Y1	HI-1P4.6K-L-Y1	HI-1P5K-L-Y1	HI-1P6K-L-Y1
Battery Type	Li-ion					
Battery Voltage Range [V]	40 ~ 60					
Max. Charge / Discharge Current [A]	75	75	100	100	125	135
Rated Power [W]	3000	3680	4000	4600	5000	6000
Communication Interface	CAN, RS485					

• Back-up

	HI-1P3K-L-Y1	HI-1P3.68K-L-Y1	HI-1P4K-L-Y1	HI-1P4.6K-L-Y1	HI-1P5K-L-Y1	HI-1P6K-L-Y1
Rated Output Power [W]	3000	3680	4000	4600	5000	6000
Rated Output Apparent Power [VA]	3000	3680	4000	4600	5000	6000
Switch Time [ms]	< 10					
Rated Grid Voltage [V]	L / N / PE, 230					
Rated Grid Frequency [Hz]	50					
Max. Output Current [A]	13	16	17.4	20	21.7	26.1
Total Harmonic Distortion, THDv	< 3% (Linear load)					
Max. Output Fault Current (Peak and Duration) [A]	90 @ 3 μs					
Inrush Current (Peak and Duration) [A]	90 @ 3 μs					
Max. Output Overcurrent Protection [A]	81					

- Efficiency

	HI-1P3K-L-Y1	HI-1P3.68K-L-Y1	HI-1P4K-L-Y1	HI-1P4.6K-L-Y1	HI-1P5K-L-Y1	HI-1P6K-L-Y1
Max. Efficiency						98.0%
Euro Weighted Efficiency						97.1%
Max. Battery Discharge Efficiency						94.7%

- Protection & Feature

	HI-1P3K-L-Y1	HI-1P3.68K-L-Y1	HI-1P4K-L-Y1	HI-1P4.6K-L-Y1	HI-1P5K-L-Y1	HI-1P6K-L-Y1
DC Reverse Polarity Protection						Yes
PV String Current Monitoring						Yes
Insulation Resistor Monitoring						Yes
Residual Current Monitoring						Yes
Anti-islanding Protection						Yes
Method of Active Anti-islanding						Frequency Shift
AC Overcurrent Protection						Yes
AC Short-circuit Protection						Yes
AC Overvoltage Protection						Yes
Overvoltage Category						OV II for DC Port, OV III for mains
DC Switch						Yes
Pollution Degree						III
Surge Protection Device, SPD						DC Type II / AC Type II
Rapid Shutdown, RSD						Optional

- General Data

	HI-1P3K-L-Y1	HI-1P3.68K-L-Y1	HI-1P4K-L-Y1	HI-1P4.6K-L-Y1	HI-1P5K-L-Y1	HI-1P6K-L-Y1
Dimensions (W x H x D Bare Machine) [mm]						461 x 482 x 208
Net Weight [kg]						27
Installation						Wall-mounted
Operation Temperature [°C]						-25 ~ +60 (> 45 Derating)
Operation Humidity						0-95% RH, No Condensing
Protection Degree						IP66
Max. Operating Altitude [m]						4000 (> 2000 Derating)
Cooling Method						Natural Convection
Noise Emission [dB]						< 40
Topology						Non-isolated
Display						LED Indicators; Integrated Wi-Fi / 4G + APP
Signal Input and Output						DRM, 1 × DI, 3 × DO
Standby Consumption [W]						< 5

- Standard Compliance

	HI-1P3K-L-Y1	HI-1P3.68K-L-Y1	HI-1P4K-L-Y1	HI-1P4.6K-L-Y1	HI-1P5K-L-Y1	HI-1P6K-L-Y1
Grid Regulation						AS / NZS 4777.2:2020
Safety Regulation						IEC/EN 62109-1, IEC/EN 62109-2
EMC						IEC/EN 61000-6-1, IEC/EN 61000-6-3



YINERGY DIGITAL POWER TECHNOLOGY CO., LTD.

Add.: Building 4 & 5, No.161 Yuancheng Road, Qiantang District, Hangzhou, Zhejiang, China

E-mail: globalsupport@yinergy-solar.com

Web: www.yinergy-solar.com

Copyright © 2024 Yinergy Digital Power Technology Co, Ltd. All Rights Reserved.